

Campus Design Code

Contents

	Page
Introduction	4
Scope	6
Design Code Zones	8
Material Performance Criteria	10
Design Considerations	12
Campus Zone	14
Student Life	26
Parkland Zone	32
Key Arrival Points	42
Campus Quads	50
Design Principles	54
Materials Overview	56
Key Areas	58
Key Area 1	60
Key Area 2	62
Key Area 3	64
Materials Selection	66
Furniture Selection	78
Lighting	92

“A world class public realm for its Whiteknights Campus”

“Rationalise and unify the palette of public realm materials and furniture”





The University of Reading has a long term ambition to deliver a world class public realm for its Whiteknights Campus. This ambition is matched by a desire to rationalise and unify the palette of public realm materials and furniture across the campus to facilitate a more cohesive long term management and maintenance strategy. The Landscape Materials Design Code forms a key component in achieving these twin objectives.

The Code is not intended to deliver a one off wholesale reconstruction of the existing landscape and public realm. As new developments, upgrades and replacement works are programmed to suit the operational and financial priorities of The University, The Code will be an accessible key point of reference to ensure a coordinated public realm is created.

This design code does not provide designs for specific areas but rather gives guidance to be utilised by The University's in house team and or designers associated with individual development proposals. The guide should be read in conjunction with the Campus Routes Strategy.

SCOPE

The Design Code will cover the whole of the Whiteknights Campus. To ensure The Code is a usable and relevant document the overall area has been divided into a series of zones which are illustrated on the plan overleaf. These zones will ensure that the guidance on materials reflects the requirements of broad areas of the campus while also allowing the available budgets to be effectively targeted at the highest priority areas.

The Code covers surface materials and furniture. The Code does not address signage, soft landscape (planting) or lighting.

 Extent of Whiteknights Campus



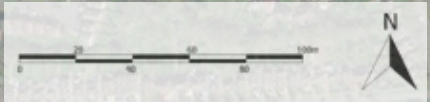

DESIGN CODE ZONES

The Design Code is organised around five zones. These zones which are illustrated on the adjacent plan are as follows:

1. CAMPUS

The Outer Campus: This area comprises the academic areas surrounding the two quads as well as the cluster of academic buildings accessed from Whiteknights Road

 Sports & Recreation: A large area of the campus zone is dedicated to sports and recreation, including training and sports facilities.

2. STUDENT LIVING

Student Living: This zone is made up of the two main residential areas for university students and staff on campus.

3. PARKLAND

Parkland: As a defining feature of the Whiteknights campus this broad swathe of open landscape is located to either side of the main lake and extends south to include the open areas along the south eastern boundary of the campus adjacent to Wilderness Road.

4. KEY ARRIVAL POINTS

Key Arrival Points: There are three main combined vehicular and pedestrian arrival points to the Whiteknights Campus. While limited in their geographical extent these three locations are of critical importance to the perception of the campus to visitors, students and staff.

5. THE UNIVERSITY QUADS

The University Quads: This zone comprises the two central quads of the Whiteknights Campus adjacent to the Palmer Building, URS Building and University Library. These areas have been the subject of more detailed design proposals and are covered in more detail on the last section of this Design Code.

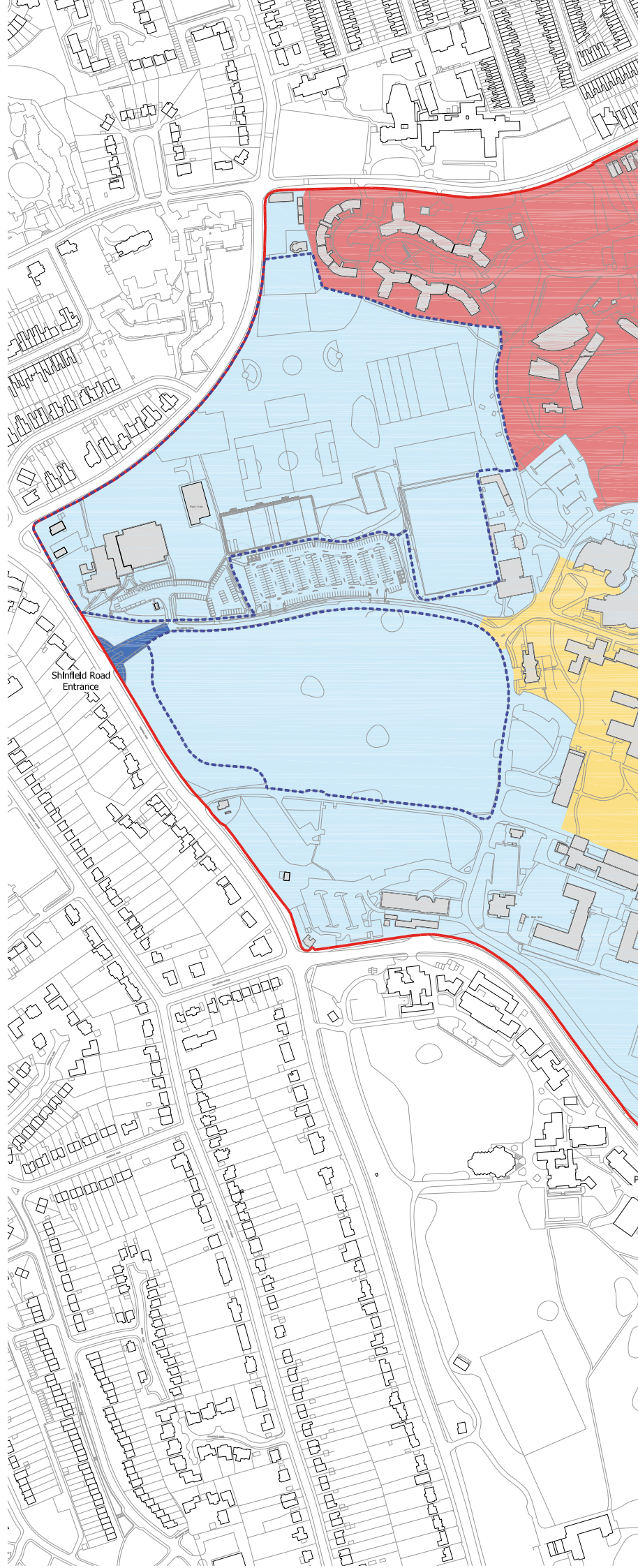

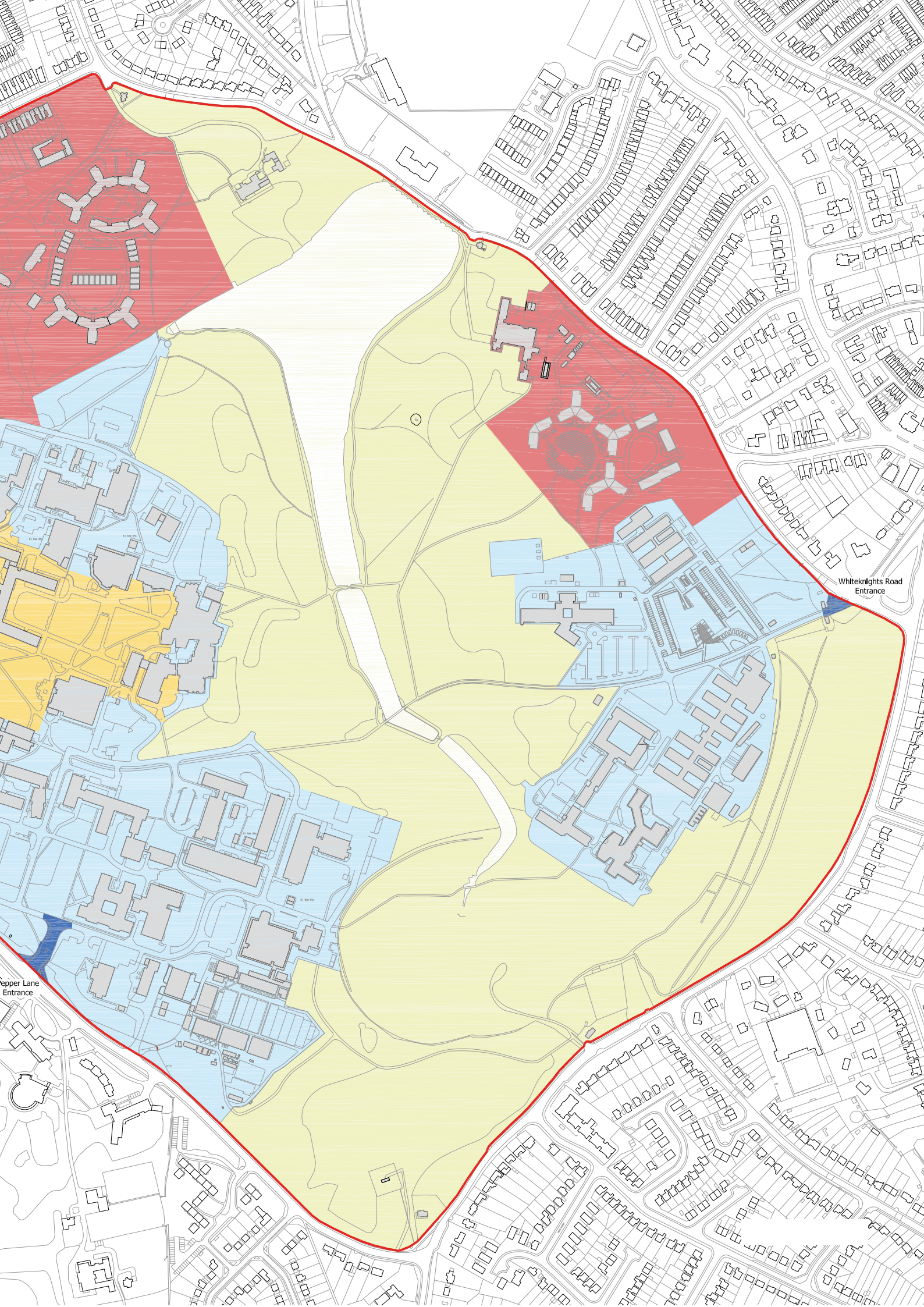

Pepper Lane Entrance

Whiteknights Road Entrance

MATERIAL PERFORMANCE CRITERIA

A set of simple requirements applied to all zones that will inform the further detailed design and specification of hard materials and furniture.

Basic requirements

All materials selection should demonstrate compliance with the following guidelines:

ETHICAL MATERIALS

Preference to use responsibly sourced materials. Where this isn't possible demonstrate that the most sustainable option has been selected and the quantity minimised. Consider environmental impact by reducing transport burden, material life span, construction methods and recycled content.



APPROPRIATENESS

Materials and furniture to be fit for purpose and meet British Standard Guidance for specification such as tolerance in surface deviation and non slip qualities, vehicle loading.



AESTHETICS

A coordinated range of colours and unit sizes that comply with a Campus wide strategy. Consider warm and welcoming colours that give a high quality appearance and low planning risk.



END OF LIFE

All materials to be durable, maintainable and where possible fully recyclable to avoid generating unnecessary waste.



MAINTENANCE

Materials selected are to be robust, hard wearing, dense and of limited porosity and colour fast. Material selection should consider reasonable means of cleaning and maintenance using standard cleaning products.



BIODIVERSITY

All external planting where considered as part of this design code should comply with the recommendations of the Head of Grounds Maintenance who will ultimately undertake maintenance responsibility.



DESIGN CONSIDERATIONS

Additional design consideration for all new areas of landscape development.

PLANTING

To avoid badly located or poorly accessed planting beds, future development needs to consider the movement and access of pedestrians and vehicles, including parking bay access. Any proposed planting beds need to be sensibly located ensuring the viability, sustainability and maintenance of planting. Avoid planting that could become a fire-hazard and design to reduce the risk of rodents. i.e. avoid large areas of dense shrubs.



FURNITURE

Furniture preferably located on hard surfaces with sufficient access to be cleaned and maintained. Any furniture located in soft landscaping needs to include a mowing strip with adequate depth to avoid damage to furniture and equipment.



PAVING

Vehicle loading where appropriate. Providing sufficient turning radii and suitable materials in areas of high risk to vehicle run over. Drainage and service covers set out to align with paving, specified to withstand vehicle loading and located to allow for easy maintenance access.

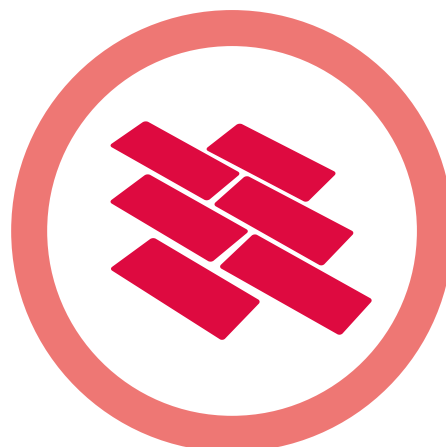

NOISE

When locating seating and gathering spaces consideration should be given to the impact of noise on adjacent learning facilities and residential areas.



SMOKING & WASTE

Smoking is not permitted within 10m of arrival and entrance spaces. Seating and gathering areas outside of this space to provide sufficient waste management for cigarettes. Litter bins are to be located strategically on key movement routes, junctions and in seating areas. Any new development within the campus should ensure the required amount of bins are provided to meet demand.



CLIMATE & PROXIMITY

For all new landscape proposals consider how the micro climate impacts the proposed development. When including any landscape feature review the proximity to other facilities, their requirements and potential impact.



CAMPUS
ZONE

CAMPUS ZONE

USE & FUNCTION

The academic areas of the Campus zone comprise; education, leisure, sports and recreation, office and support facilities. These areas are subject to large amounts of pedestrian movement from staff and students attending lectures, lessons and commuting from key locations across the campus.

The ambition for the campus zone is to better co-ordinate and rationalise existing routes, entrances and spaces. Including:

1. Clearly defined entrances

These spaces are critical to the user experience and play an important role in the impression and experience formed by visitors.

2. Touchdown/ Breakout spaces

A social touchdown space close to the entrance that may include leaning posts, cafe space or seating for visitors and students to congregate informally and for short periods.

3. Safe and secure cycle parking

Safe and secure cycle storage located close to the building entrances within a dedicated zone.

4. Clearly defined routes

Legible access along defined routes that connect the key spaces and entrances with the wider wayfinding strategy.





Mathematics &
Information Technology
Main entrance
Mathematics and Statistics

University of
Reading

CAMPUS ZONE

DESIGN INTERVENTION

This section aims to highlight primary design areas and demonstrate the connections between them within the campus zone.

The campus zone should provide for;

 Safe movement of pedestrian and cycle traffic:

Direct and efficient routes strategically planned and clearly identified for connections between key locations.

 Key building entrances:

Visibly identified with high quality materials, clear and accessible with potential for storage and breakout spaces.

 Rationalised and co-ordinated street furniture

NOTE:

The design principles set out within this section are to illustrate the continuity of design across the campus, as and when they are developed.

Each area needs to be individually reviewed to assess the extent of change and should be agreed with the occupants of each facility.

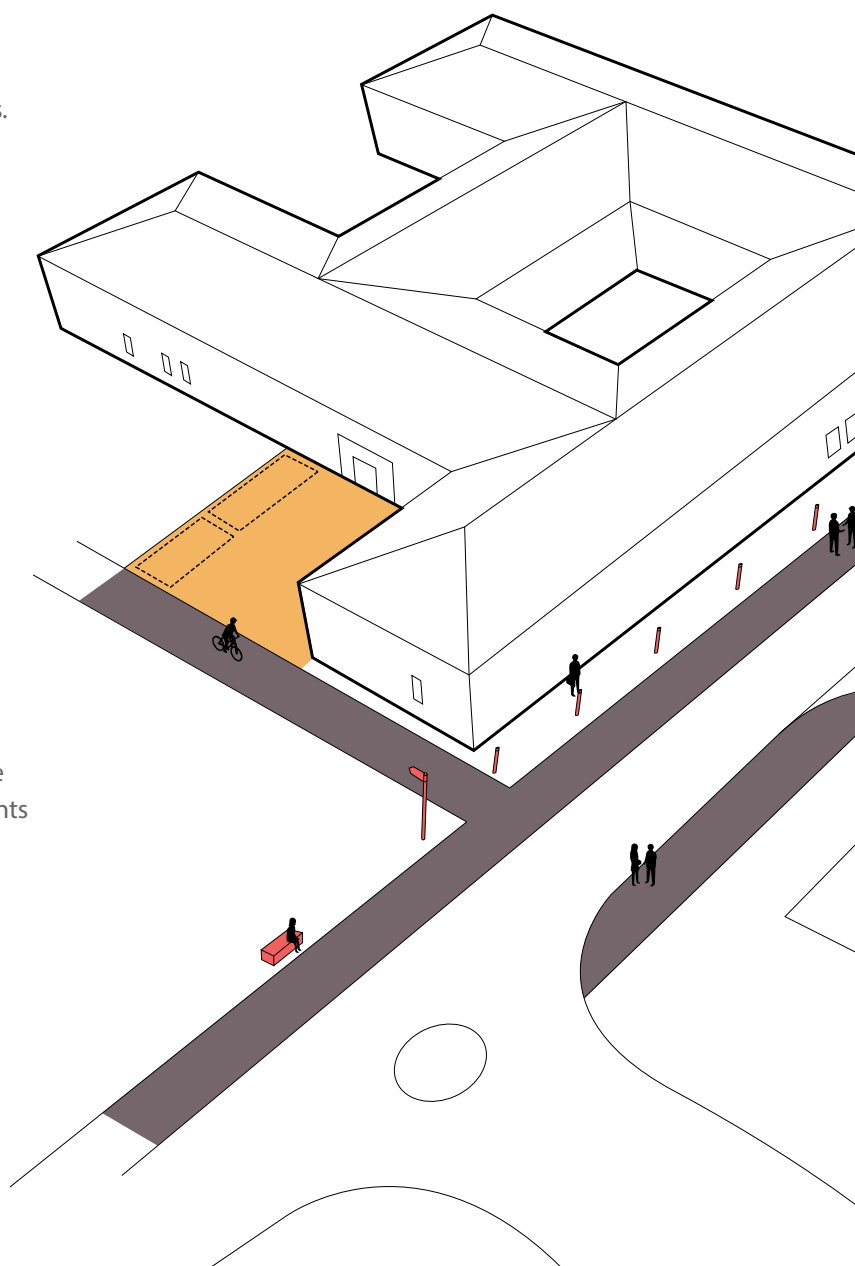

Campus Zone

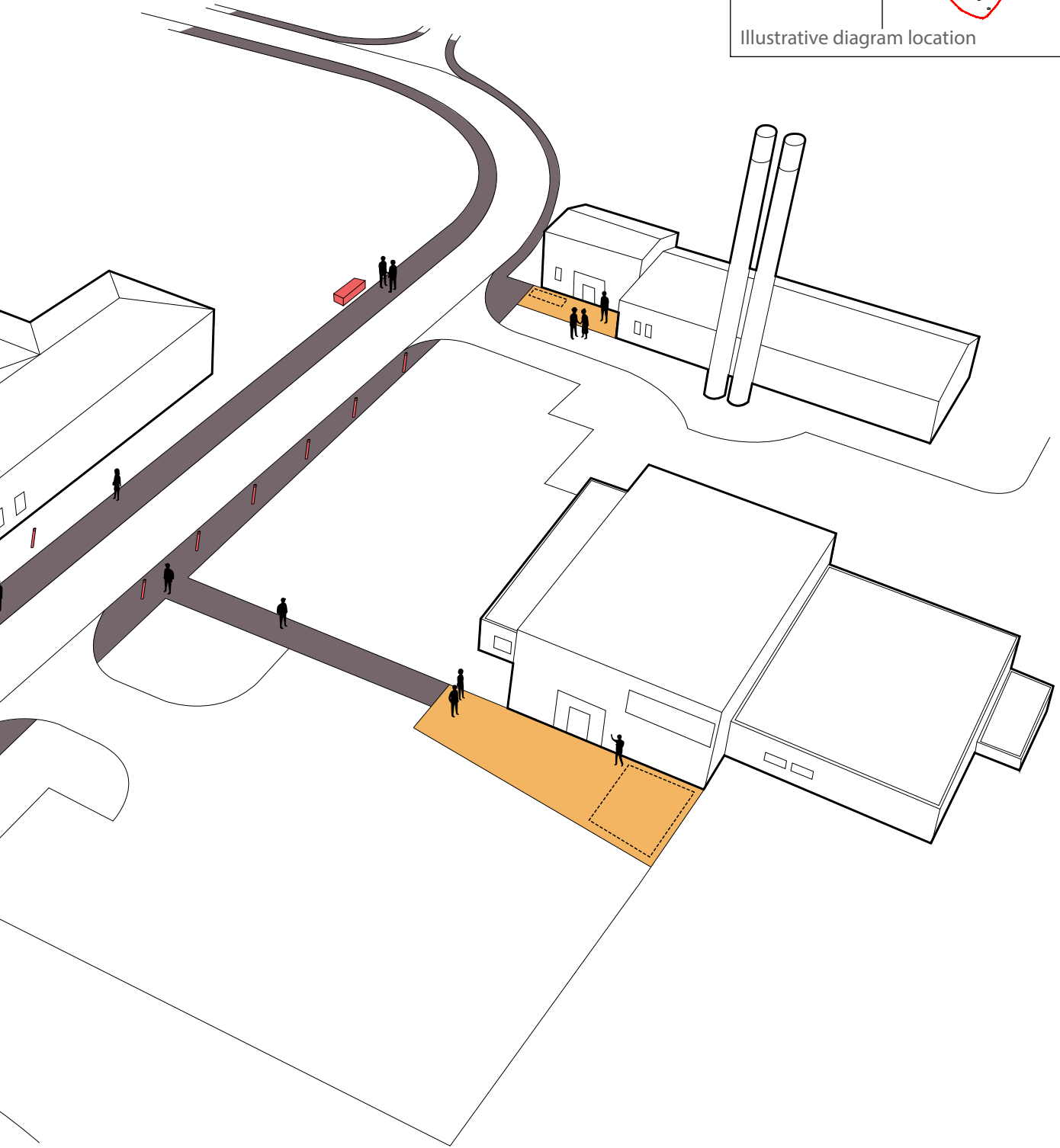
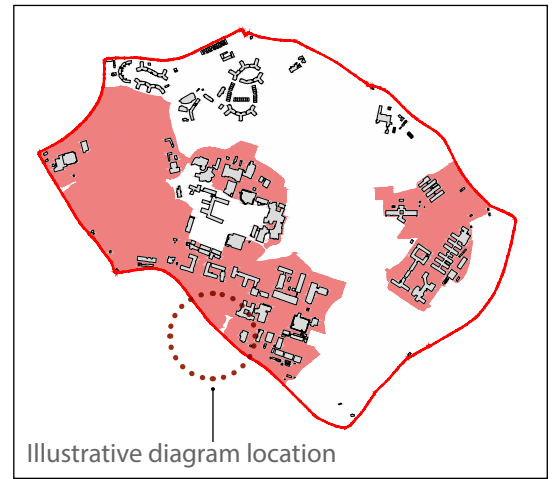

* Diagram is for illustrative purposes only and is not a reflection of actual design intent

CAMPUS ZONE

TYPICAL SPATIAL ARRANGEMENTS

The correct arrangement of space at key building entrances will ensure an enjoyable, legible and safe environment that is consistent across the campus zone. This should include the consideration of both material and furniture resulting in:

1. Clearly defined entrances

Areas of recognisable high quality flag paving that extend from the threshold and distinguish the entrance as important from the access routes to it. The extent of this 'welcome mat' of paving will be determined by the hierarchy of entrance and anticipated footfall. Entrances need to be free from obstruction with a clear line of sight to reinforce a direct physical and visual connection.

2. Touchdown/ Breakout spaces

Social touchdown spaces need to be located close to the entrances, with sufficient separation to accommodate the furniture and students who will congregate there informally for short periods. The material selection will need to be of sufficient quality to reflect the proximity to the entrance, but be mindful of cleaning and maintenance needs associated with its function.

3. Safe and secure cycle parking

These can be either covered or open, but need to be located in areas of good natural surveillance that provide security and user confidence, such as a dedicated zone located close to the building entrance. The material selection of furniture and cycle stores needs to be unified across the campus, with considered transition pieces and surface materials to ensure a cohesive approach to the public realm.

4. Clearly defined routes

These are areas of high footfall that need to be robust in their material selection, such as a rolled surface with defined edging. Routes need to be obstruction free and form part of an entrance sequence that creates a physical and visual connection towards the building entrances.

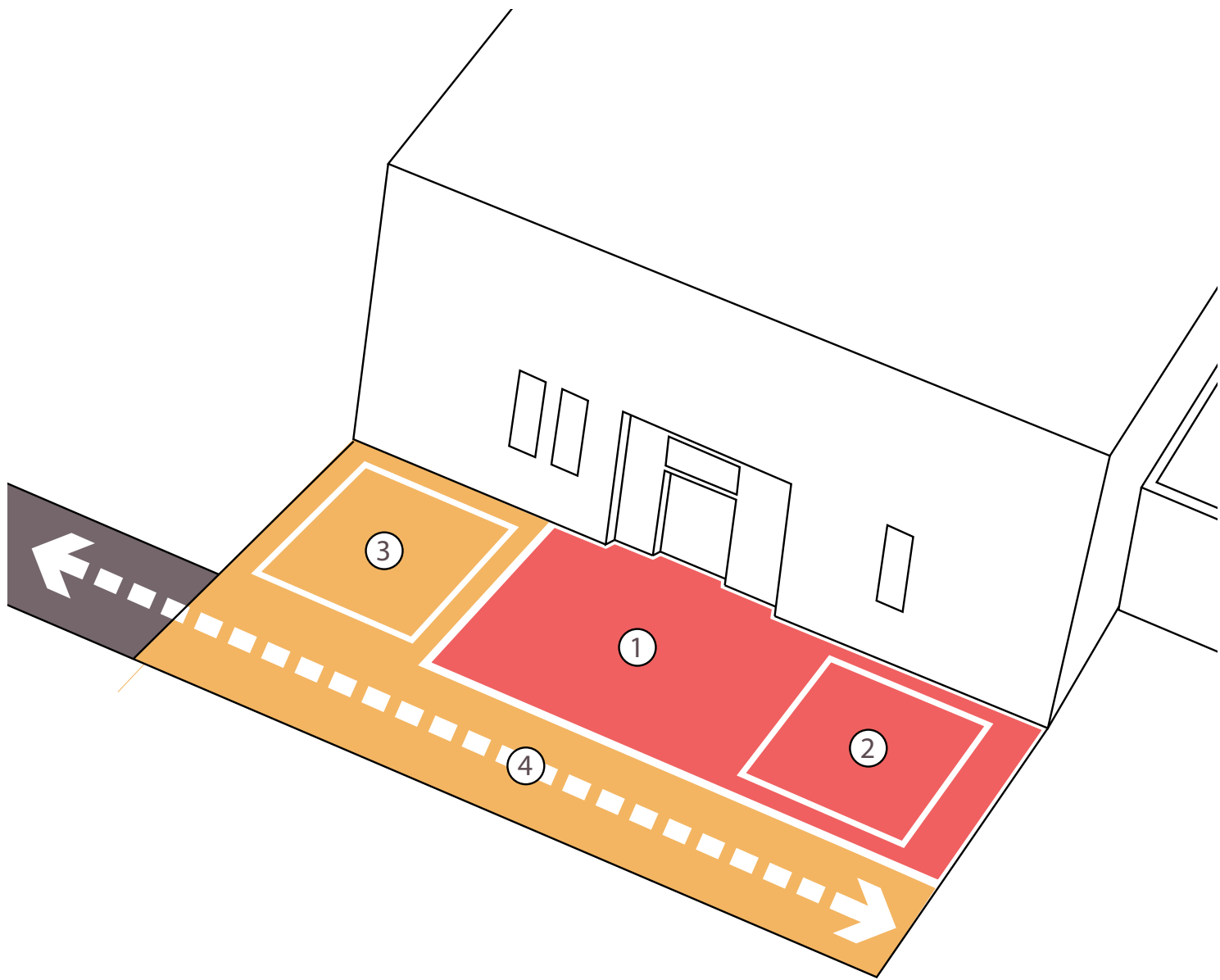





CAMPUS ZONE

SPECIFICATION

The materials and furniture palette will provide the University team with a rationalised range of suitable higher quality and affordable options for the use in future campus development to help achieve a co-ordinated public realm.

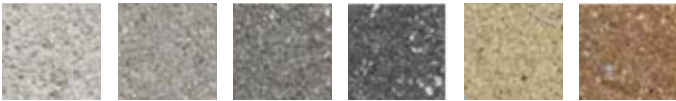
ENTRANCE/ DOORSTEP

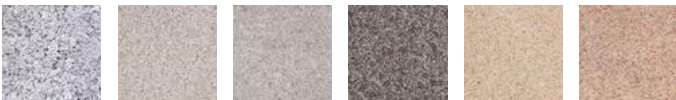
Affordable		<p>Block paving Hard wearing, affordable surface laid in a herringbone pattern. A vibrant long-lasting colouring is required to ensure a long life span. Sizing to a 2:1 ratio with a thickness for vehicular loading where necessary (200x100x80 or similar approved) Colours to be a range of tonal greys to buff shades.</p>	
		<p>Textured aggregate block paver An alternative to granite with a higher quality feel but at an affordable price. Sizing to a 3:1 ratio with a thickness for vehicular loading where necessary (300x100x80 or similar approved) Colours to be a range of complementary greys to buff shades.</p>	
Higher quality		<p>Natural stone granite planks A high quality finish for areas of higher profile. Flamed finish. Sizing to a 3:1 ratio with a thickness for vehicular loading where necessary (300x100x80 or similar approved) Colours to be a range of greys to buff shades.</p>	

EDGING

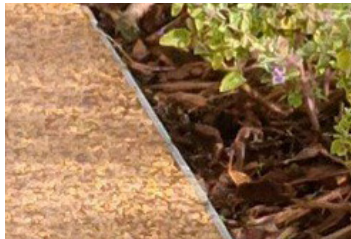
Affordable		<p>Pre-cast Concrete Edge Highly durable edging to frame and separate materials and edges. Option to be laid flush with upstand. Square edge approximate size 150x50</p>
Higher quality		<p>Aluminium Edge Flexible edging with fixed to foundation. Natural milled finished</p>

ROUTE & PATHWAYS

Affordable ↑



Tarmacadam
 Hard wearing and economical material used throughout the campus to create safe and level movement. Mix to be specified by Engineer

Higher quality ↓



Textured aggregate block flag paving
 A robust and affordable option to achieve a higher quality aesthetic to route of higher profile.
 Sizing to a 1:1 ratio with a thickness for vehicular loading where necessary (450x450x50 or similar approved)
 Colours to be a range of complementary greys to buff shades.

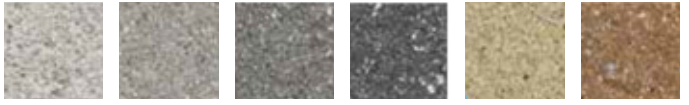

KERBS

Affordable ↑



Concrete Kerb
 Manufactured to British standards and highly durable to provide a safe environment adjacent roads. 225,125 bullnose or similar approved

Higher quality ↓



Textured Pre-cast Concrete Kerb
 A more aesthetic option with a lightly textured surface. 225x145 squared edge or similar approved

BOLLARDS



Square steel profile bollard
Simple and stylish L-profile to fit seamlessly with surface materials.
Powder coated steel RAL 7016 with RAL 3028 (or similar) contrast strip, set in contrast to paving to aid the visually impaired. Optional drop down bollard, secured with 1602 padlock.

Aluminium alloy circular bollard
Powder coated aluminium alloy with the possibility to embossed the University emblem into the face of the bollard to create a stylish and functional bollard.
Powder coated steel RAL 7016 with optional drop bollard.

SEATING & BINS



Timber Bench
Stylish timber and steel bench with hardwood certificated FSC untreated timber requiring minimal maintenance.
All steel Powder coated steel RAL 7016 with optional timber back rest



Double waste stream bin
In accordance with The University of Reading Bin/ waste management strategy bins require a double waste stream with cigarette disposal at an affordable price.
Powder coated RAL 7016 (standard Broxap colour) .80L Double waste stream 160L total.
Rectangular aperture for general waste and round aperture for recycling with built-in ashtray to top of unit. No laser cut lettering and available space for signage.

*For further information refer to the University:

Waste Management Specification for New Builds and Refurbishments

CYCLE SHELTERS



Bike Shelter

Contemporary angular steel framed bike shelter with glass, metal or timber roof construction. Optional enclosed sides and lockable compartments. Powder coated RAL 7016



Bike Stand

Sheffield style steel bike stand with mid rail. Finish - Galvanised, stainless steel, or powder coated RAL 7016. Fixed - Root fixed or recessed hidden bolt and plate fixing. Recommended 1m distance between stands, 0.8m minimum.

COLOUR CO-ORDINATION

The colours below aim to create a standard for furniture introduced through future development.

UNIFIED STANDARD

A standard colour that can be applied to more permanent features such as furniture (bike shelters, bins, benches etc) to create continuity across the campus as areas are re-furnished or replaced. The colour RAL 7016 has been chosen as a timeless but stylish option which can be found as standard from most manufacturers.

ACCENT COLOUR

The accent colour can be applied to features requiring attention for safety or aesthetic reasons. Adding contrast to bollards or a splash of colour to bike hoops. The colour could be applied in various ways from reflective strips to coated paints.

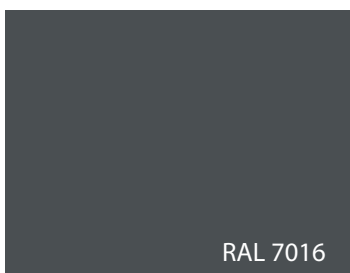

STUDENT LIVING

STUDENT LIVING

USE & FUNCTION

This area of the campus is largely run by the University Partnership Program (UPP) and as such has its own approach for landscape within these area.

This area of the campus provides student housing with associated landscapes, bespoke bike shelters, bin stores and substations with a design language that includes a materials and furniture palette.

MAINTENANCE

Although this area is run by the UPP, the maintenance of the area is still under the management of the University Grounds Maintenance Team. As such any future development in this area should adhere to the material performance criteria, design considerations and waste managements strategy set out in this document.





STUDENT LIVING

RECOMMENDATIONS

The UPP are responsible for designing and implementing future developments within this area. The following provides recommendations of materials and furniture which will better integrate with the distinctive style of the University Campus.

MATERIALS



Tarmacadam

Hard wearing and economical material used throughout the campus to create safe and level movement. Mix to be specified by Engineer



Block paving

High quality material with a softer feel, indicating pedestrian priority, slowing vehicular traffic. Roma, Bracken colour, mixed size pack or similar.



Block kerb

Continuing the softer appearance to road edges. Roma, Bracken colour or similar.



Textured aggregate block paver

Mix of Light grey, silver grey & midnight grey, 200x100x80 or similar.

FURNITURE



Study seating, Informal clusters of tables and chairs, providing splashes of colour. Casting in ground, powder coated RAL 3028 & 7016



Pre-cast concrete bench with stylish and robust with an optional backrest.



Aluminium alloy circular bollard

Powder coated aluminium alloy with the possibility to embossed the University emblem into the face of the bollard to create a stylish and functional bollard.

Powder coated steel RAL 7016 with RAL 3028 (or similar) contrast strip, set in contrast to paving to aid the visually impaired. Optional drop down bollard.



Timber Bench

Stylish timber and steel bench with hardwood certificated FSC untreated timber requiring minimal maintenance.

All steel Powder coated steel RAL 7016 with optional timber back rest

BINS



Double waste stream bin

In accordance with The University of Reading Bin/ waste management strategy bins require a double waste stream with cigarette disposal at an affordable price.

Powder coated RAL 7016 (standard Broxap colour) .80L Double waste stream 160L total. Rectangular aperture for general waste and round aperture for recycling with built-in ashtray to top of unit. No laser cut lettering and available space for signage.

*For further information refer to the University:

Waste Management Specification for New Builds and Refurbishments

PARKLAND

PARKLAND

USE & FUNCTION

The Parkland area of the campus is historically and ecologically important with a strong link to the University image and as such needs to be treated with a sensitive approach, with as little impact as possible.

The Parkland is used by not just students and staff but local residents for recreational use including walking, running, relaxing, photography and dog walking. The area also harbours the main movement routes into and around the campus with usable footpaths and connections to key campus locations.

The ambition for the Parkland zone is to maintain and enhance this existing landscape for the continued use of staff, students and residents by assuring:

1. Consistent and clear movement routes

Maintaining existing routes, clearly defined with sufficient route widths for areas of high footpath.

2. Areas of opportunity

At key areas around the Parkland the provision of low impact furniture can help to provide opportunities for interaction.





PARKLAND ZONE

DESIGN INTERVENTIONS

The diagram below demonstrates the different types of movement route surrounding the Parkland with different requirements to address sensitive areas and areas of a higher footfall.

The Parkland Zone should provide for:

 Ecologically and historically sensitive route

These routes are close to habitats and historical elements and as such the application of any new materials needs to consider their potential impact.

 Safe and easy movement of pedestrian and cycle traffic

Direct and efficient routes, hard wearing and identified for connections through the Parkland.

 Rationalised and environment appropriate furniture

Appropriate to the setting of the Parkland area a range of furniture including seating, bollards and bins in rationalised areas.

NOTE:

The design principles set out within this section are to illustrate the continuity of design across the campus, as and when they are developed.

Each area needs to be individually reviewed to assess the extent of change and should be agreed with the occupants of each facility.

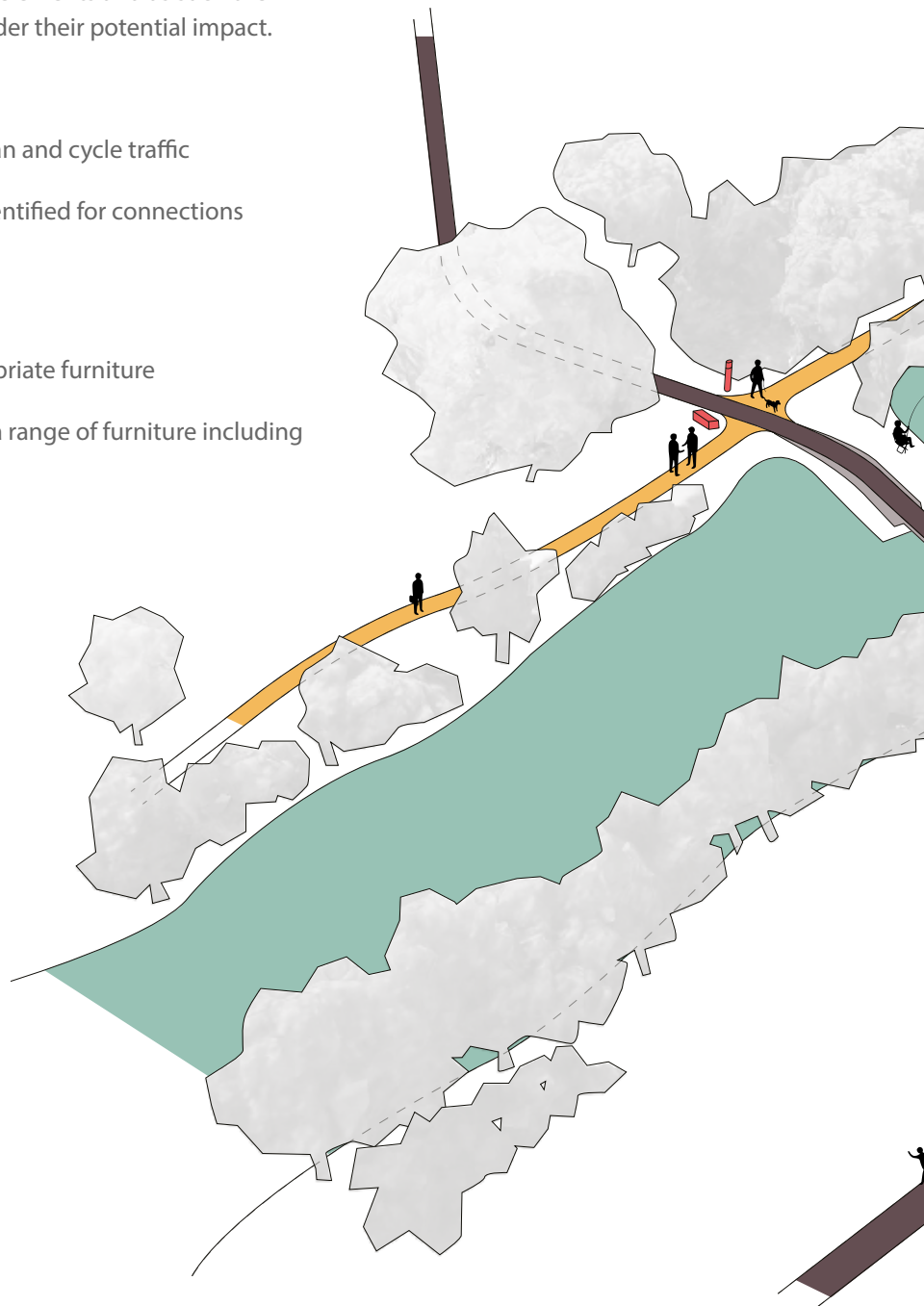

Parkland Zone

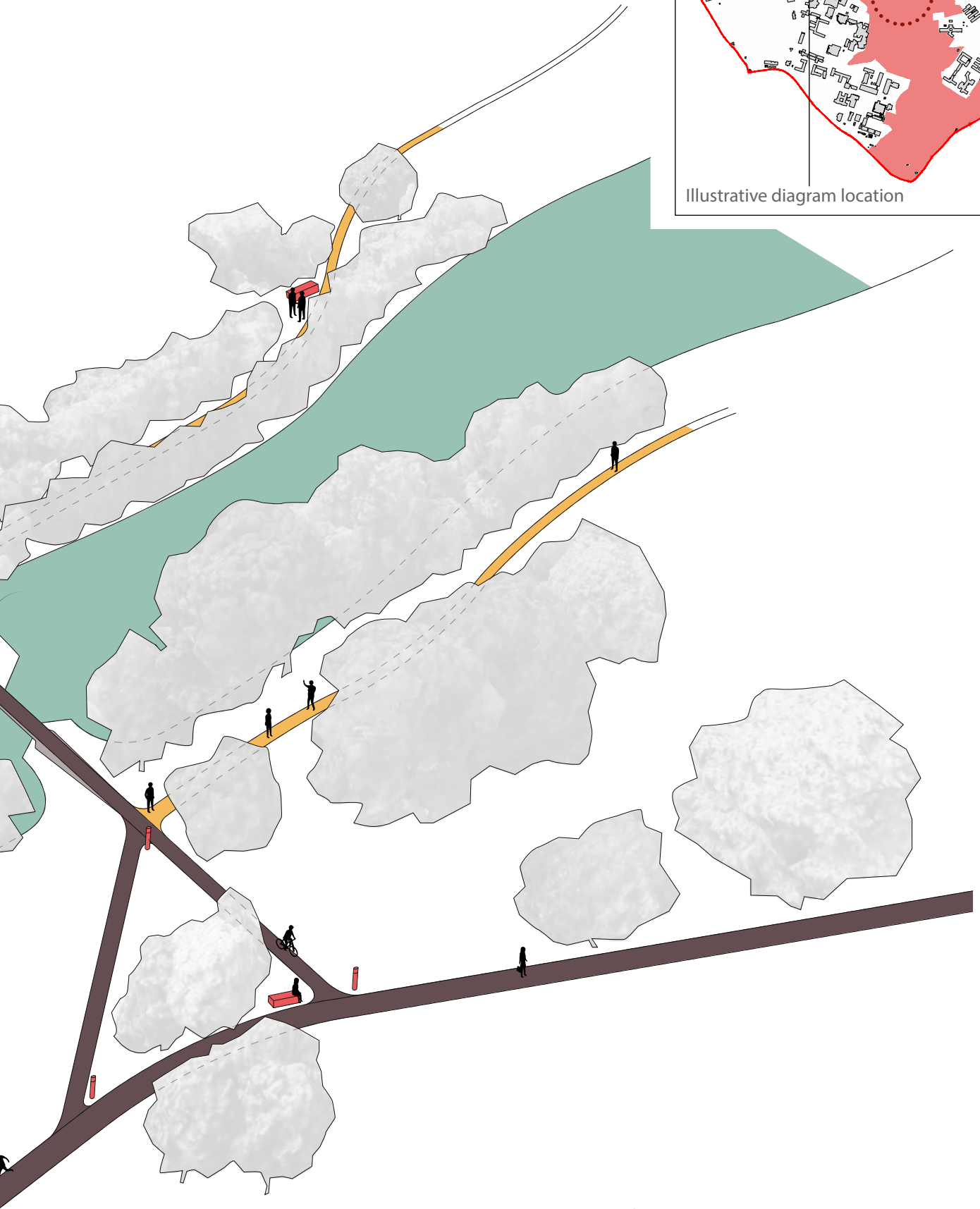
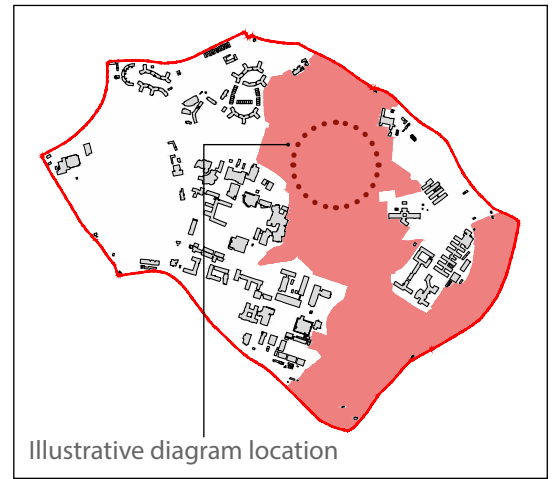

* Diagram is for illustrative purposes only and is not a reflection of actual design intent

PARKLAND ZONE

TYPICAL SPATIAL ARRANGEMENT

The extent of any works done within the Parkland zone will need to be optimised to achieve a low impact solution considering both materials and furniture in defined areas:

1. Clearly defined routes

Areas of both robust and potential low impact materials creating the structure of the route with clear and suitable edging to maintain the boundary of the footpath. The full width on these route should be clear from furniture and suitable to accommodate the appropriate footfall.

2. Defined furniture area

Any furniture to be introduced into the Parkland zone to be defined in an area close to the route to allow for easy access and to maintain activity away from sensitive areas.

3. Buffer zone

A buffer zone clear from furniture and hard materials to maintain distance from sensitive landscapes.

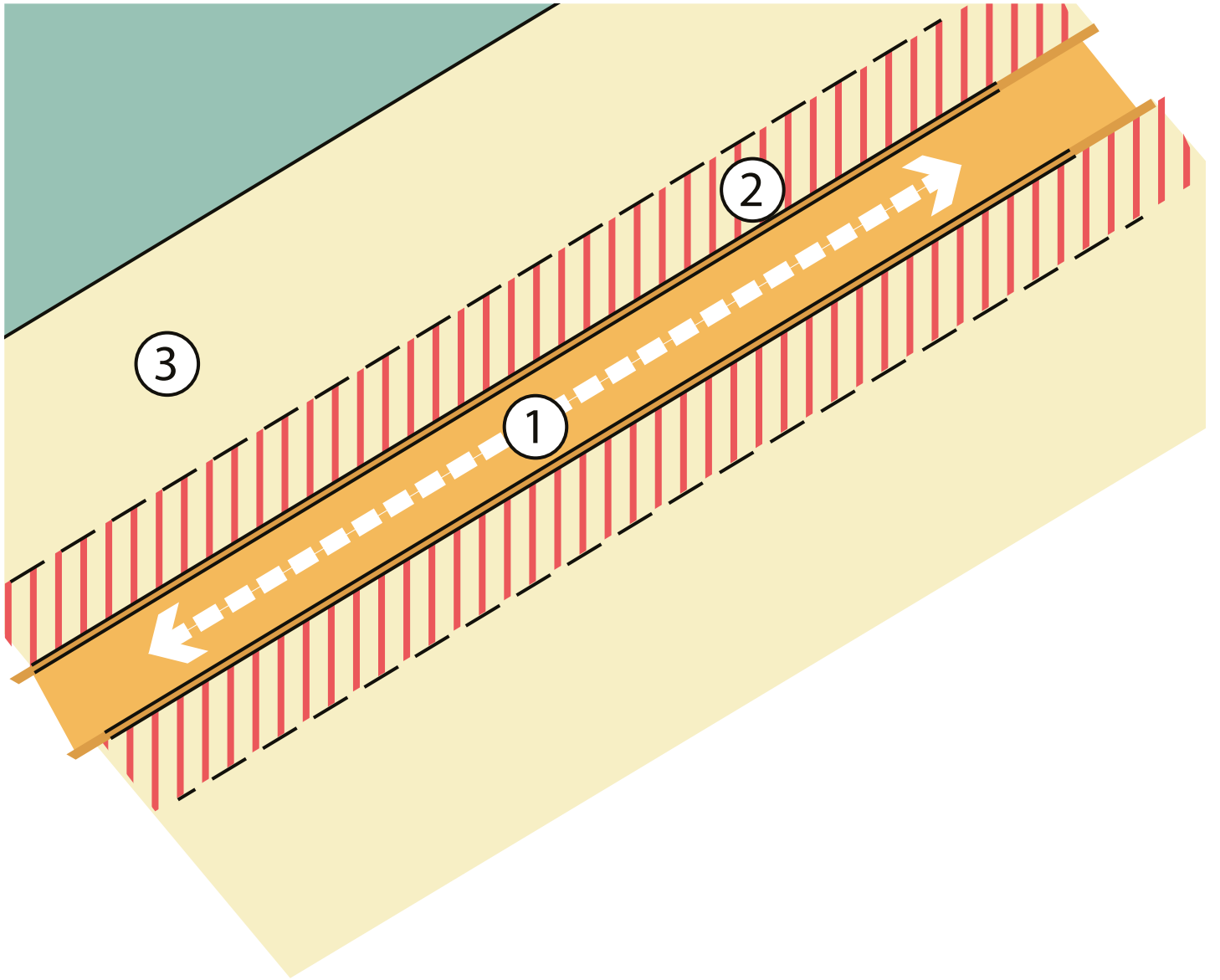

PARKLAND ZONE

SPECIFICATION

The materials and furniture palette will provide the University team with a rationalised range of suitable higher quality and affordable options for the use in future campus development to help achieve a co-ordinated public realm.

PATHWAYS AND ROUTES

<p>Durable</p>		<p>Tarmacadam Hard wearing and economical material used throughout the campus to create safe and level movement. Mix to be specified by Engineer</p>
<p>Low impact</p>		<p>Self binding gravel Environmentally friendly natural aggregate graded to fines. Buff colouration to match loose aggregate footpaths.</p>
		<p>Loose aggregate footpaths Environmentally friendly natural aggregate laid, lightly rolled and levelled. Colouration to be light buff, approximately 10-20mm grade.</p>

BINS



Double waste stream bin
In accordance with The University of Reading Bin/ waste management strategy bins require a double waste stream with cigarette disposal at an affordable price.
Powder coated RAL 7016 (standard Broxap colour) .80L Double waste stream 160L total.
Rectangular aperture for general waste and round aperture for recycling with built-in ashtray to top of unit. No laser cut lettering and available space for signage.

*For further information refer to the University:

BOLLARD

Waste Management Specification for New Builds and Refurbishments



Timber Bollard
All wood to be FSC hardwood. Square in profile with the option of a drop bollard.

EDGING

Durable



Pre-cast Concrete Edge

Highly durable edging to frame and separate materials and edges. Option to be laid flush and with upstand. Square edge approx size 150x50

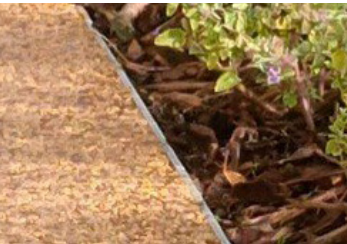

Aluminium Edge

Flexible edging with fixed to foundation. Natural milled finished



Timber plank & peg edging

Used in areas requiring a sensitive edging solution. All timber to be FSC and suitably treated to external in ground contact conditions. Approx 40mm thickness.

Low impact

FURNITURE

Durable



Timber Bench

Stylish timber and steel bench with hardwood certificated FSC untreated timber requiring minimal maintenance.

All steel Powder coated steel RAL 7016 with optional timber back rest



Chunky timber Bench

Sturdy and resilient hardwood FSC untreated timber, requiring minimal maintenance.

2 plank, Straight bench approximate size 2000x450mm

Low impact

KEY ARRIVAL POINTS

KEY ARRIVAL POINTS

USE & FUNCTION

The Whiteknights campus currently has three key arrival spaces located at opposite sides of the campus. These key arrival points are critical to the user experience and play an important role in the impression formed by visitors.

Entrances need to be quickly legible, clear to navigate and distinguishable to both vehicle and pedestrian, providing:

 1. Arrival zone

A high quality landscape experience indicating the arrival into an academic environment separating from the adjacent highway.

 2. Clear pedestrian routes & crossing points

Crucial to the pedestrian user experience of the campus arrival, providing easy access in and out of the campus.





WELCOME

 University of Reading
WESTENHANTS CAMPUS | SHEFFIELD ROAD

KEY ARRIVAL POINTS

DESIGN INTERVENTIONS

The campus arrival points need to provide a safe and efficient junction whilst connecting the campus with the surrounding landscape providing:

1. Arrival zone junction

Providing for safe crossing for pedestrians and direct access for vehicles with a high quality standard to indicate the arrival on campus.

2. Safe and easy movement of pedestrian and cycle traffic

Footpaths connecting the surrounding area into the campus need to be clearly defined, direct and efficient with consideration to all possible movement opportunities.

3. Minimal furniture

A clutter free environment with minimal effective use of street furniture.

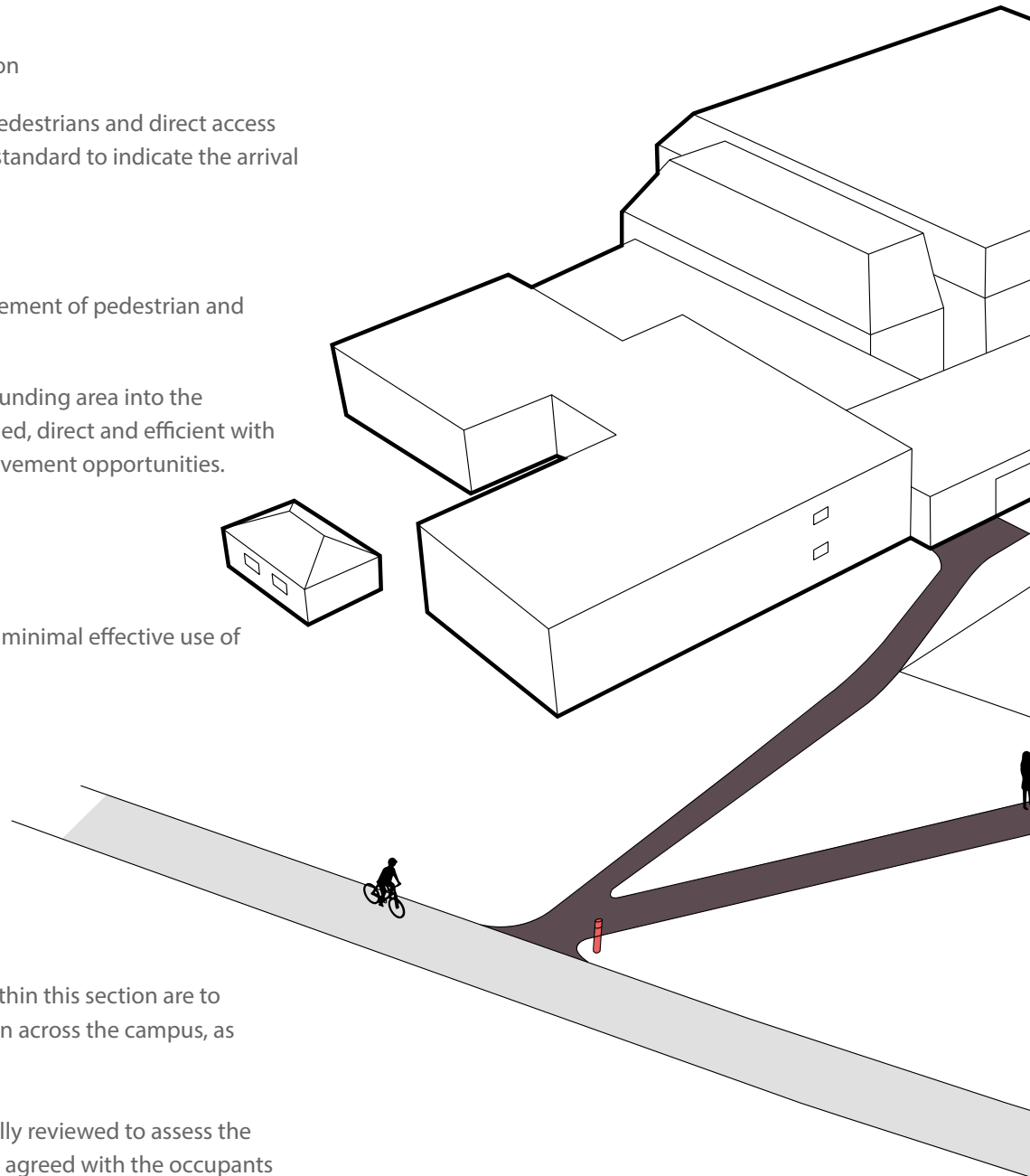

NOTE:

The design principles set out within this section are to illustrate the continuity of design across the campus, as and when they are developed.

Each area needs to be individually reviewed to assess the extent of change and should be agreed with the occupants of each facility.

Key Arrival Points Zone

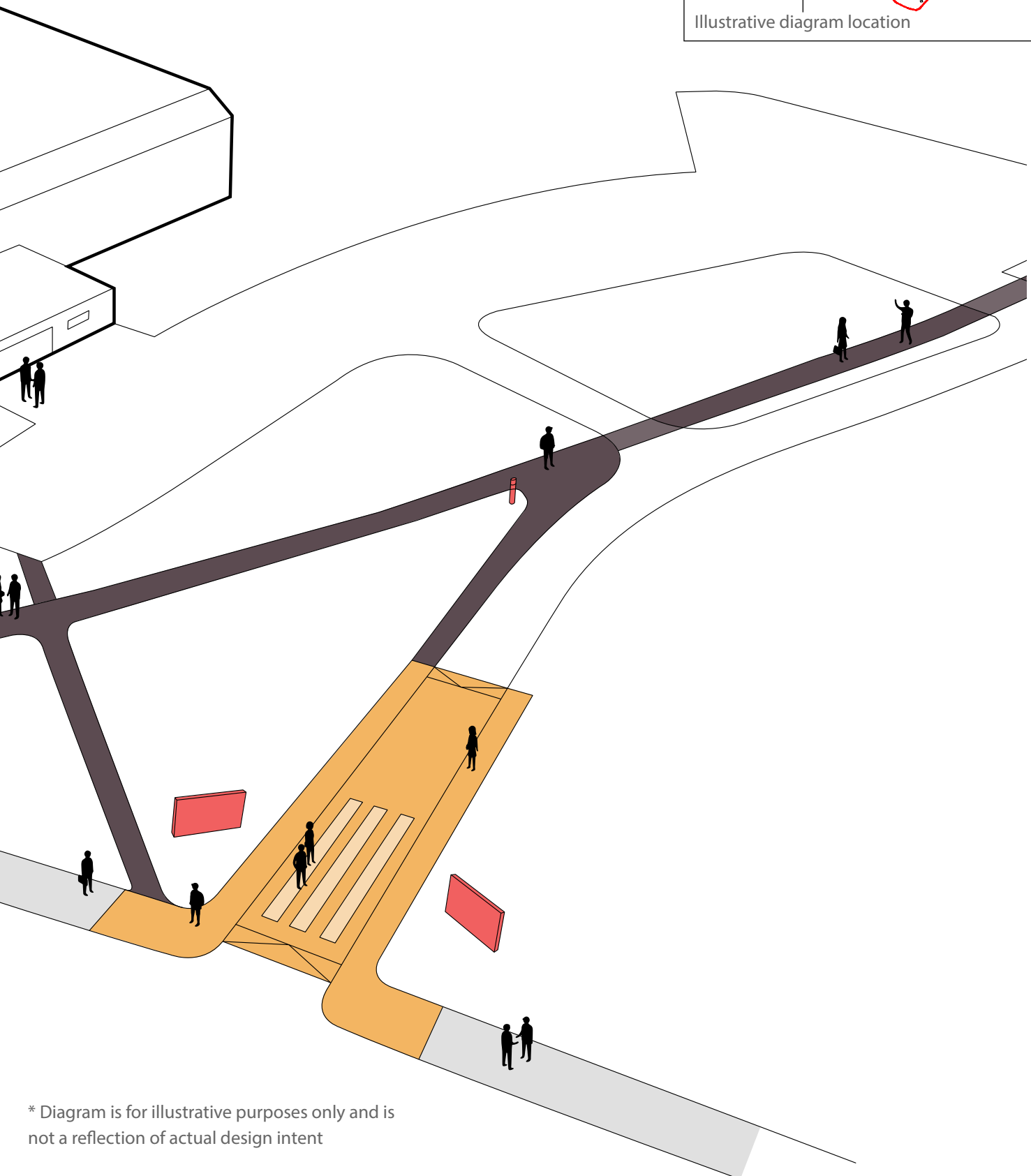
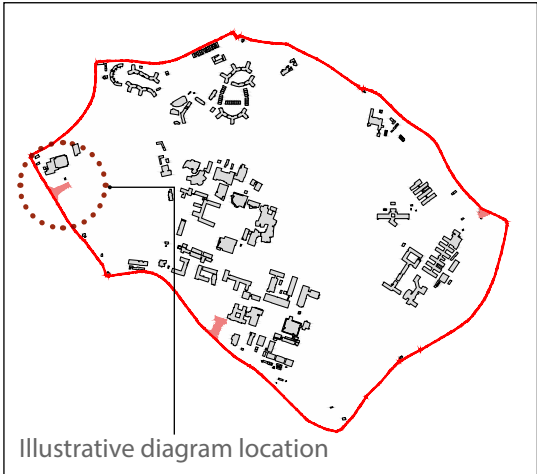

* Diagram is for illustrative purposes only and is not a reflection of actual design intent

KEY ARRIVAL POINTS

SPECIFICATION

The materials and furniture palette will provide the University team with a rationalised range of suitable higher quality and affordable options for the use in future campus development to help achieve a co-ordinated public realm.

PATHWAYS AND ROUTES

Affordable

↑

↓

Higher quality







Tarmacadam
Hard wearing and economical material used throughout the campus to create safe and level movement. Mix to be specified by Engineer

Higher quality



Granite setts
Used sparingly but introduced to lift the quality of higher profile routes. For the use as bands or framing of routes.
Sizing 100x100x100, flamed finish laid flush
Colours to be a range of complementary greys.

ARRIVAL SPACES

Affordable

↑

↓

Higher quality







Natural stone granite planks
A high quality finish for areas of higher profile. Flamed textured finish
Sizing to a 3:1 ratio with a thickness for vehicular loading (300x100x80 or similar approved)
Colours to be a range of complementary greys to buff shades.

Higher quality



Granite countrysetts
A high quality material for a contrast strip at arrival spaces.
Sizing 200x100x80, flamed textured finish
Colours to be a range of complementary greys.

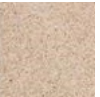

BINS



Double waste stream bin
In accordance with The University of Reading Bin/ waste management strategy bins require a double waste stream with cigarette disposal at an affordable price.
Powder coated RAL 7016 (standard Broxap colour) .80L Double waste stream 160L total.
Rectangular aperture for general waste and round aperture for recycling with built-in ashtray to top of unit. No laser cut lettering and available space for signage.

*For further information refer to the University:

Waste Management Specification for New Builds and Refurbishments

KERBS

Affordable
Higher quality



Concrete Kerb
 Manufactured to British standards and highly durable to provide a safe environment adjacent roads.
 Sizing approx 250x145 compliant with British standards, bullnose profile



Textured Pre-cast Concrete Kerb
 A more aesthetic option with a lightly textured surface.
 Sizing approx 250x145 compliant with British standards, squared edge.



Granite Kerb
 High quality, hard wearing and durable to edge higher profile route and space.
 Sizing approx 250x145 compliant with British standards, fine picked finish
 Colours to be a range of complementary greys.



BOLLARDS

Pedestrian
Vehicular



Square steel profile bollard
 Simple and stylish L-profile to fit seamlessly with surface materials.
 Powder coated steel RAL 7016 with RAL 3028 (or similar) contrast strip, set in contrast to paving to aid the visually impaired. Optional drop down bollard, secured with 1602 padlock.



Aluminium alloy circular bollard
 Powder coated aluminium alloy with the possibility to embossed the University emblem into the face of the bollard to create a stylish and functional bollard.
 Powder coated steel RAL 7016 with RAL 3028 (or similar) contrast strip, set in contrast to paving to aid the visually impaired. Optional drop down bollard.

UNIVERSITY QUADS

UNIVERSITY QUADS

Located at the heart of the Whiteknights Campus the Quads form the heart of The University. The Quads have been the subject of extensive design proposals for which a more detailed design code has been produced.

The Quad landscape section has also been produced following prior extensive consultation with key University of Reading stakeholders, which has set out the range of surface materials, external furniture and lighting to be used in the central area of the University.



Key Arrival Points Zone

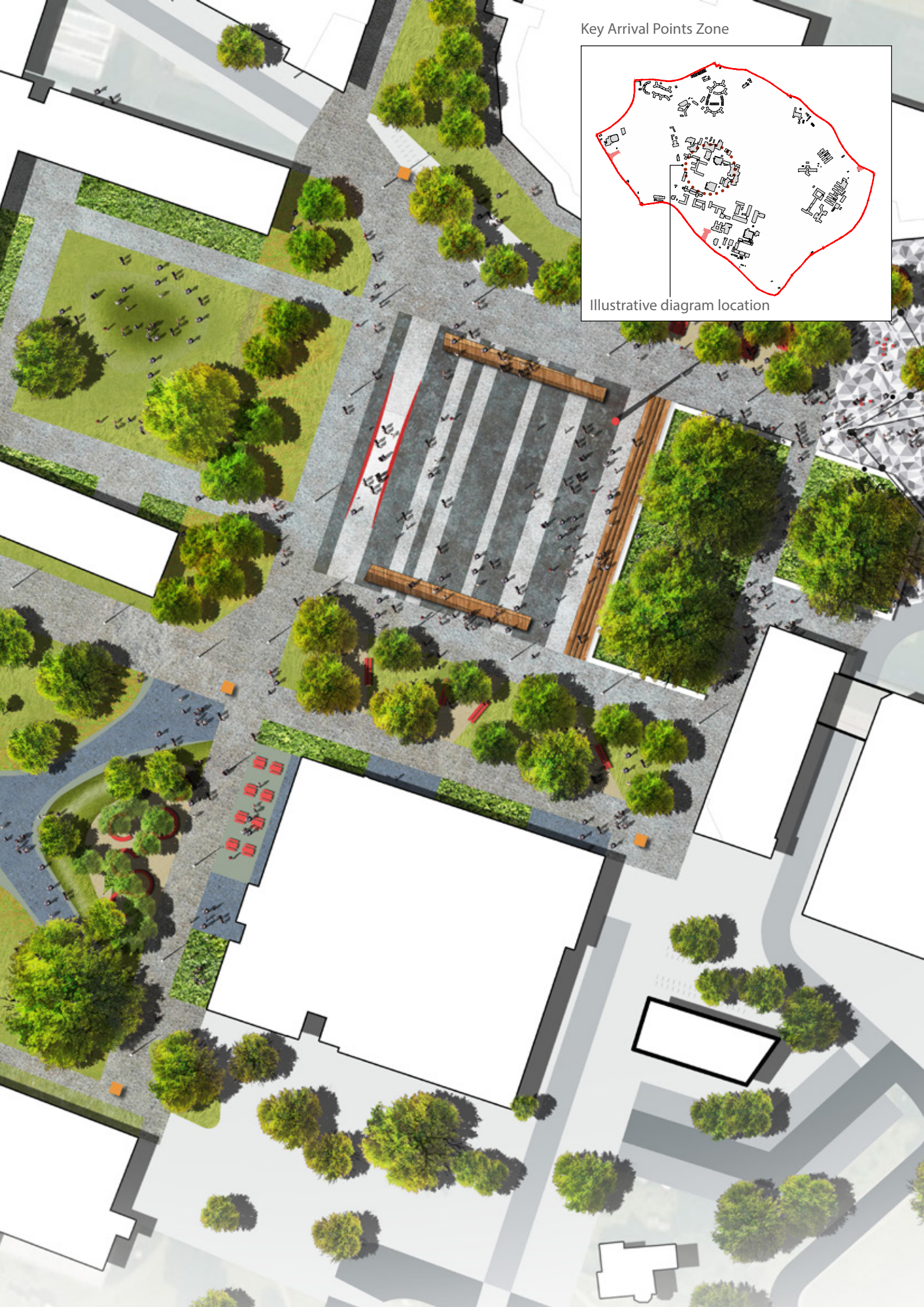
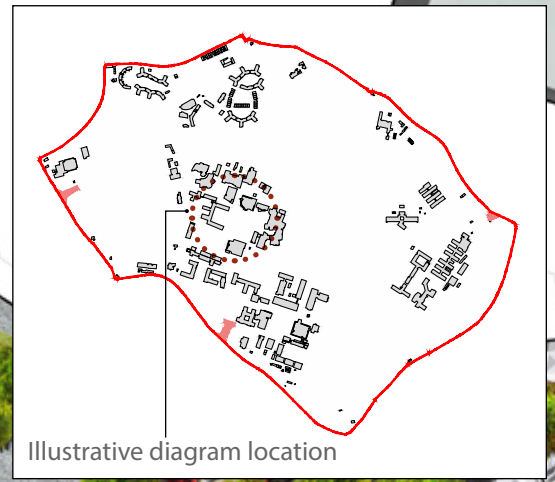

DESIGN PRINCIPLES

The wider Quad proposals identified a number of key structuring components to deliver a cohesive series of spaces within the Quads:

1. A figure of eight path network surrounds the two quads enhancing movement patterns and drawing the varied architecture surrounding the spaces together
2. The two quads are given distinctive identities reflecting their intended uses, the URS quad remains predominantly green with subtle modifications to its existing path network. The Palmer Quad is reconfigured as a space with a higher proportion of hard surface capable of hosting a wide range of events
3. The RUSU terrace is envisaged as a space with a distinct identity with a more informal character relating to the RUSU building.

Figure 1: Design Principles Diagram

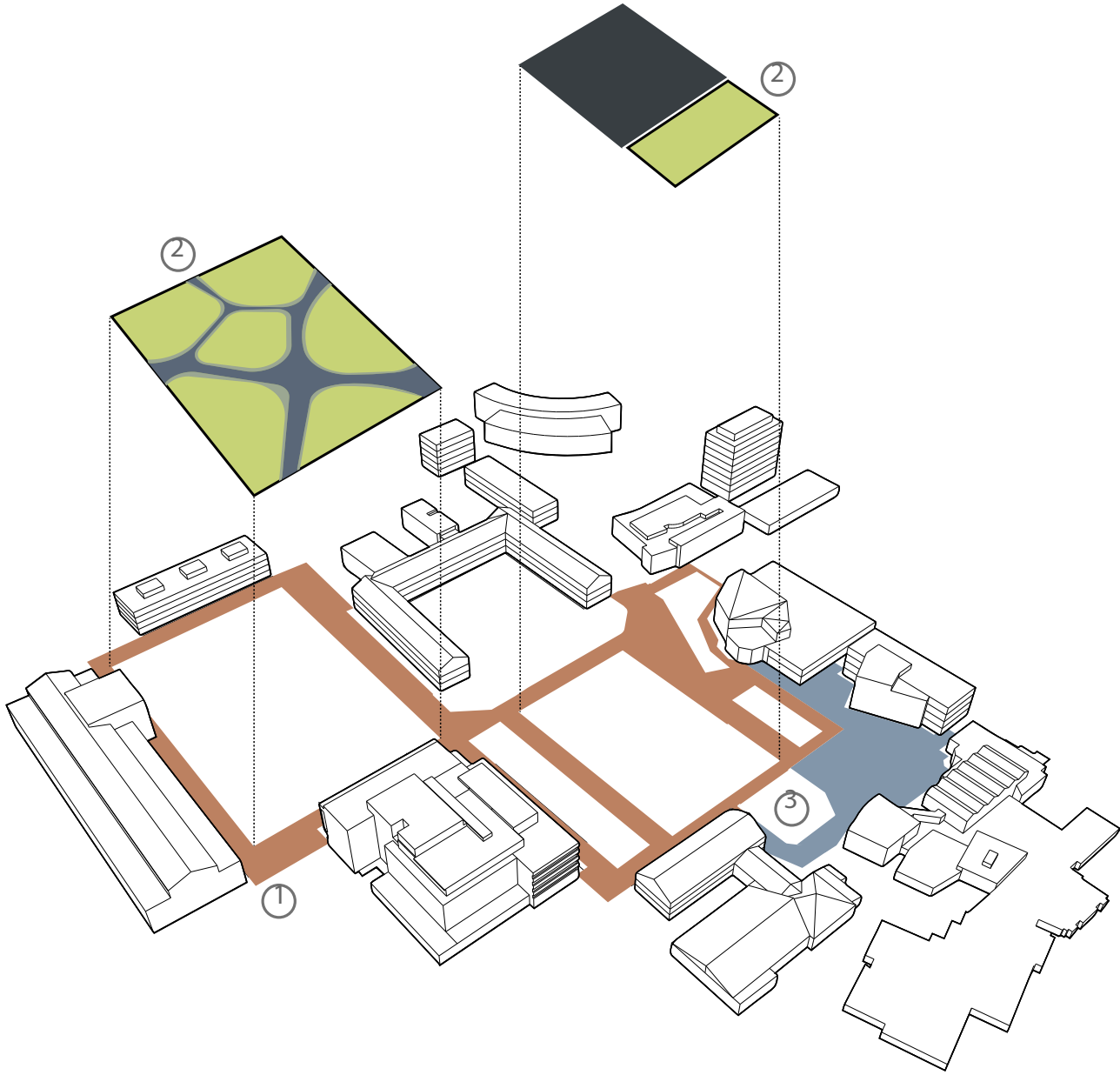

MATERIALS OVERVIEW

The adjacent diagram and the list of materials below give an overview of the palette of materials which are proposed and their broad locations. The exact layout of each key component of the masterplan is not fixed and is subject to further detailed design as the overall project progresses. The palette of materials has been selected to achieve a high quality environment, creating a sense of unity within the core campus spaces.

- The selected materials are durable able to withstand a wide range of demanding uses throughout their intended design life.
- The selected materials are suitable for all users, in a wide range of weather conditions.
- Consultation with The University’s Estates and Facilities team has ensured that the selected materials are maintainable and can be reinstated effectively following services maintenance.
- Aesthetically the materials have been selected to provide a warm colour palette avoiding large areas of monotonous grey tones.
- The available budget has been carefully targeted to deliver the highest quality materials in the most prominent and high profile areas.

Key Plan









- | | | | |
|---|--------------------------|---|----------------------------|
|  | Dutch Clay Pavers |  | Tarmacadam |
|  | Porphyry Setts |  | Self Binding Gravel |
|  | Granite Paving |  | Black Gravel |
|  | Pre Cast Concrete Paving |  | PCC Trim to Central Square |

Figure 2: Materials Plan



KEY AREAS

The following pages illustrate in more detail how the materials palette will be combined in three key areas to reinforce the aspirations of the Quads Masterplan to create attractive human scale spaces which respond to the needs of the University of Reading and allow a greater range of activities to be hosted in the external spaces of the campus. These sample areas do not reflect an update of the overall design of the masterplan but act as a test area to examine how the proposed materials work in combination.

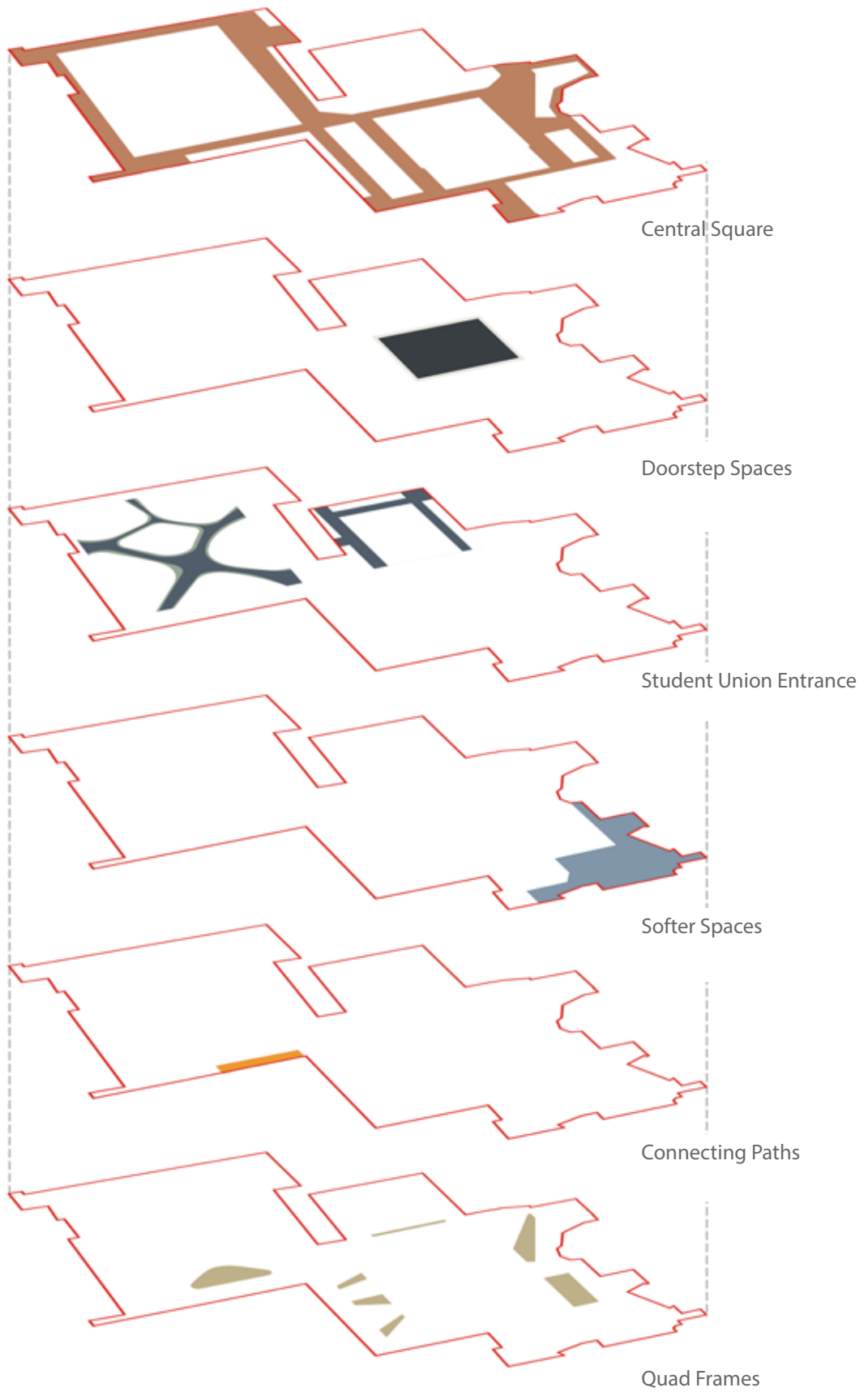
KEY AREA 1

Palmer Quad & Square

Palmer Quad is the main open space in the core area of the Whiteknights campus. The public realm proposals envisage this space as the main square for The University, a flexible space capable of hosting a wide range of events. This high profile location and flexible role determine a number of key priorities in the selection of materials:

- ① The highest quality materials in the palette reflecting its profile.
- ② Ability to accommodate a range of events and support vehicles up to and including articulated vehicles.
- ③ Rich and 'human scale' surface which provides visual interest when the square is populated by only a small number of people.
- ④ Ability to visually define the edge of the space.
- ⑤ Potential to accommodate public art into the surface of the square as part of a wider programme of public art.

Figure 3: Location of vignette

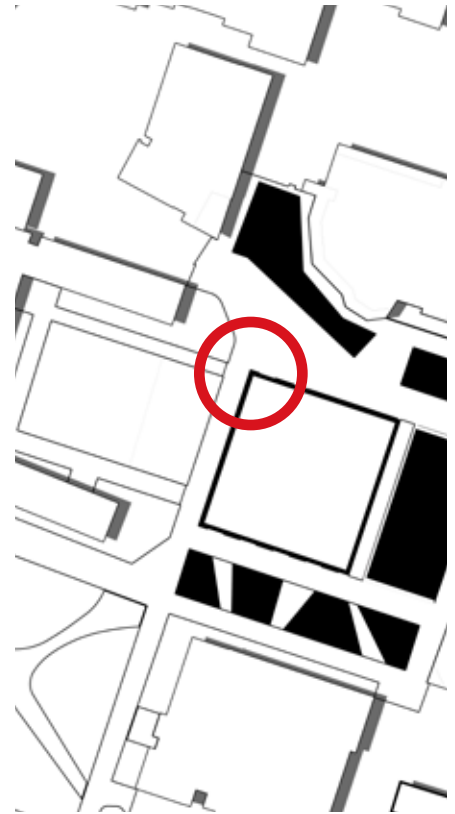

Figure 4: Vignette of Palmer Quad materials



Figure 5: Precedent images



KEY AREA 2

RUSU Terrace

The public realm strategy defined the area outside the main RUSU and Carrington buildings as visually distinct from the main Palmer Quad. The terrace is however “anchored” to the wider public realm masterplan by the ‘frame’ which runs as a continuous band around both the Palmer and URS Quads. For this area key priorities for the selection of materials included:

- ① Provision of a robust material capable of withstanding a wide range of often demanding uses including queuing for events in the RUSU building.
- ② A vibrant and lively surface which sets the space apart from the main Palmer Quad.
- ③ A surface which allows the proposed new tree planting to thrive.

Figure 6: Location of vignette

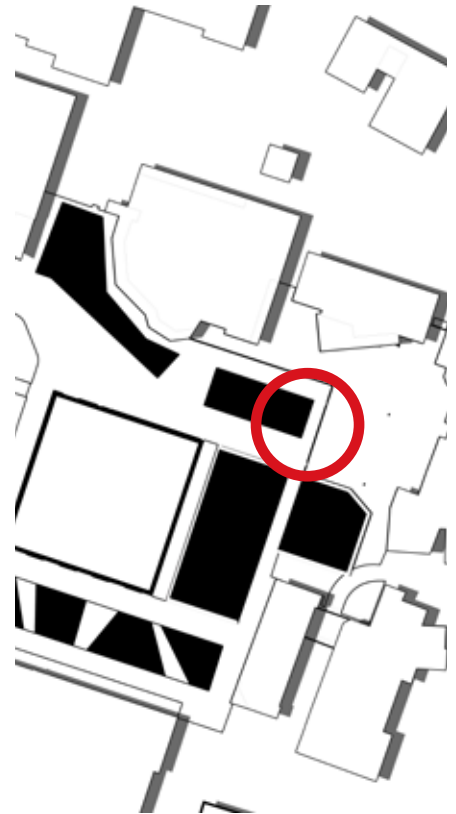
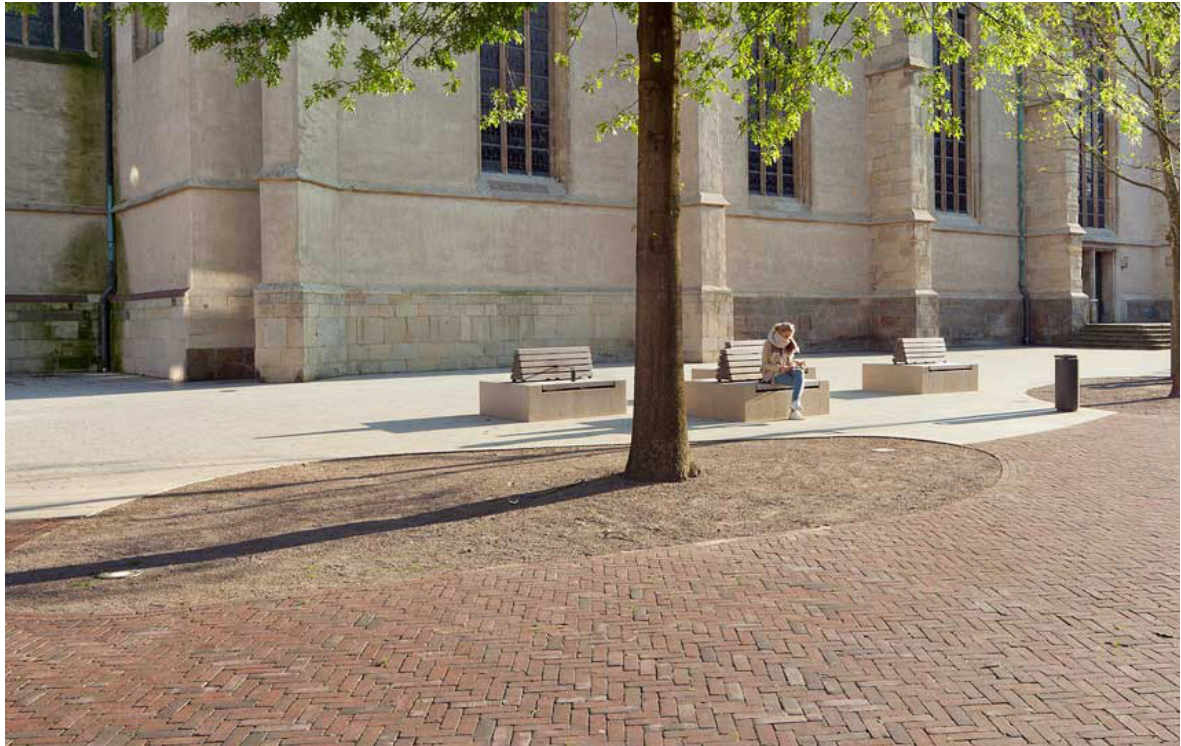

Figure 7: Vignette of Palmer Quad materials



Figure 8: Precedent images



KEY AREA 3

URS Quad

The character of the URS quad is defined in large part by its extensive tree planting. The public realm strategy seeks to maintain these trees using them as a key component to define a space with a more low key feel than the more formal Palmer Quad.

- ① Trees and lawns.
- ② Path surfacing capable of accommodating periods of large pedestrian flow but visually minimising width.
- ③ Provision of a robust material capable of withstanding high use.

Figure 9: Location of vignette

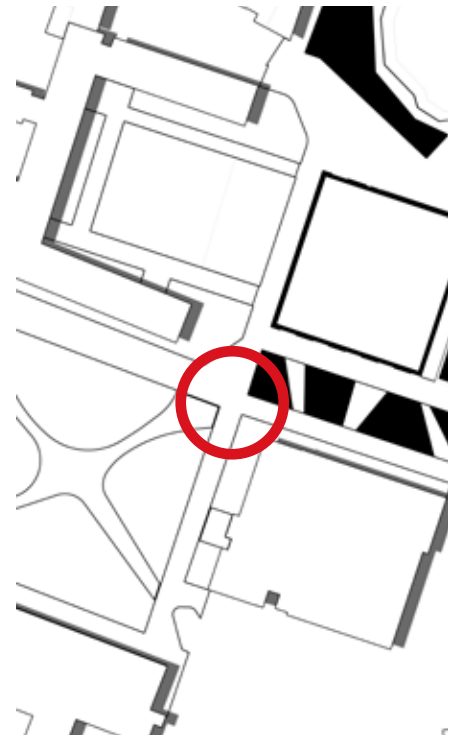

Figure 10: Vignette of Palmer Quad materials

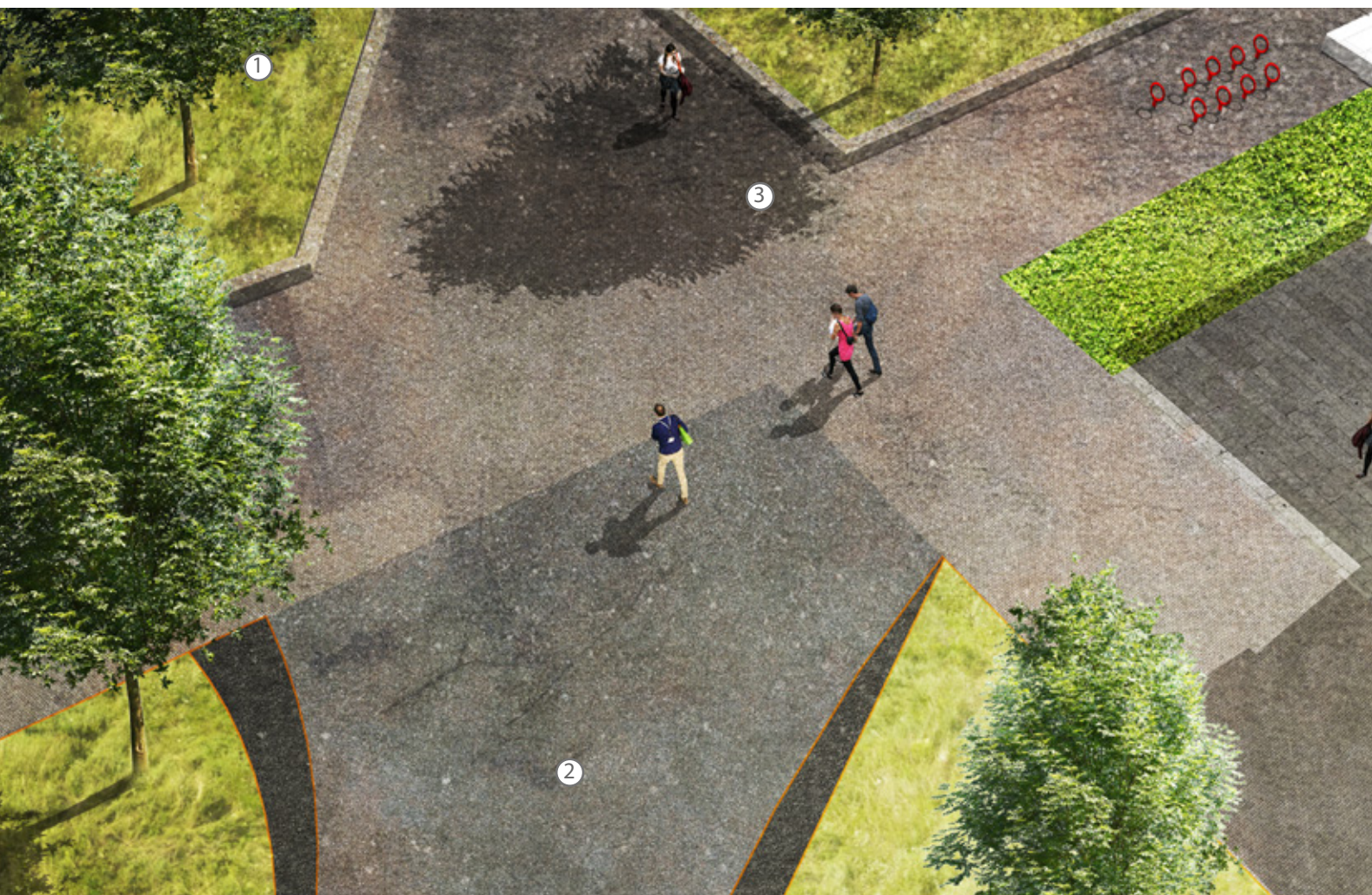

Figure 11: Precedent images



MATERIALS SELECTION

PORPHYRY SETTS

A natural stone with great colour variation and texture. Porphyry has been chosen as the main material within the Palmer Square for its high quality, traditional feel.

Figure 12: Material image

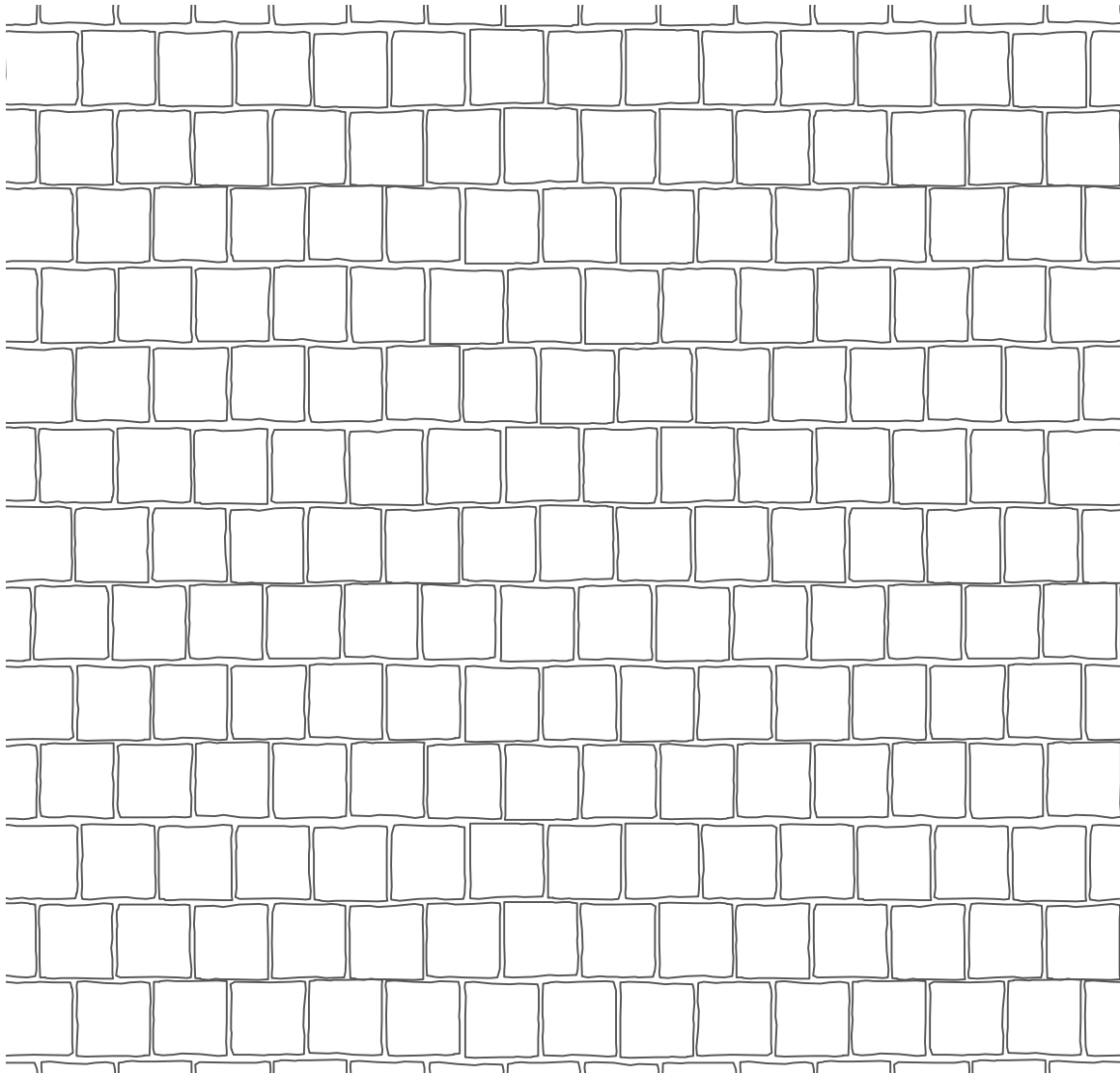

Figure 13: Material visualisation



Figure 14: Material precedent

Figure 15: Laying pattern



Product	Porphyry Setts
Bond	Random stretcher bond, minimum 45mm overlap
Dimensions	150 x 150 x 150mm
Material	Porphyry
Finish	Sawn base, split sides. 30% bush hammered top, 40% flamed top, 30% honed top
Joints	7-12mm high strength flood grouted mortar joints and mortar bed
Supplier	Hardscape www.hardscape.co.uk / 01204 565 500

DUTCH CLAY PAVERS

Dutch clay pavers are a hard wearing material that remain flexible over time and can be easily maintained. Their warmth and variation make them an ideal choice for the 'frame' which enclose the central spaces.

Figure 16: Material image

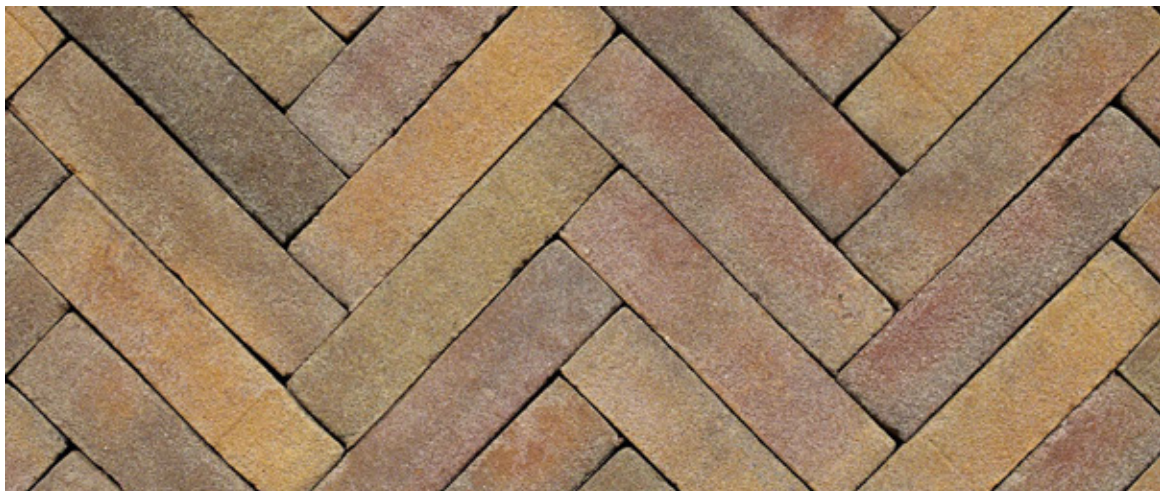
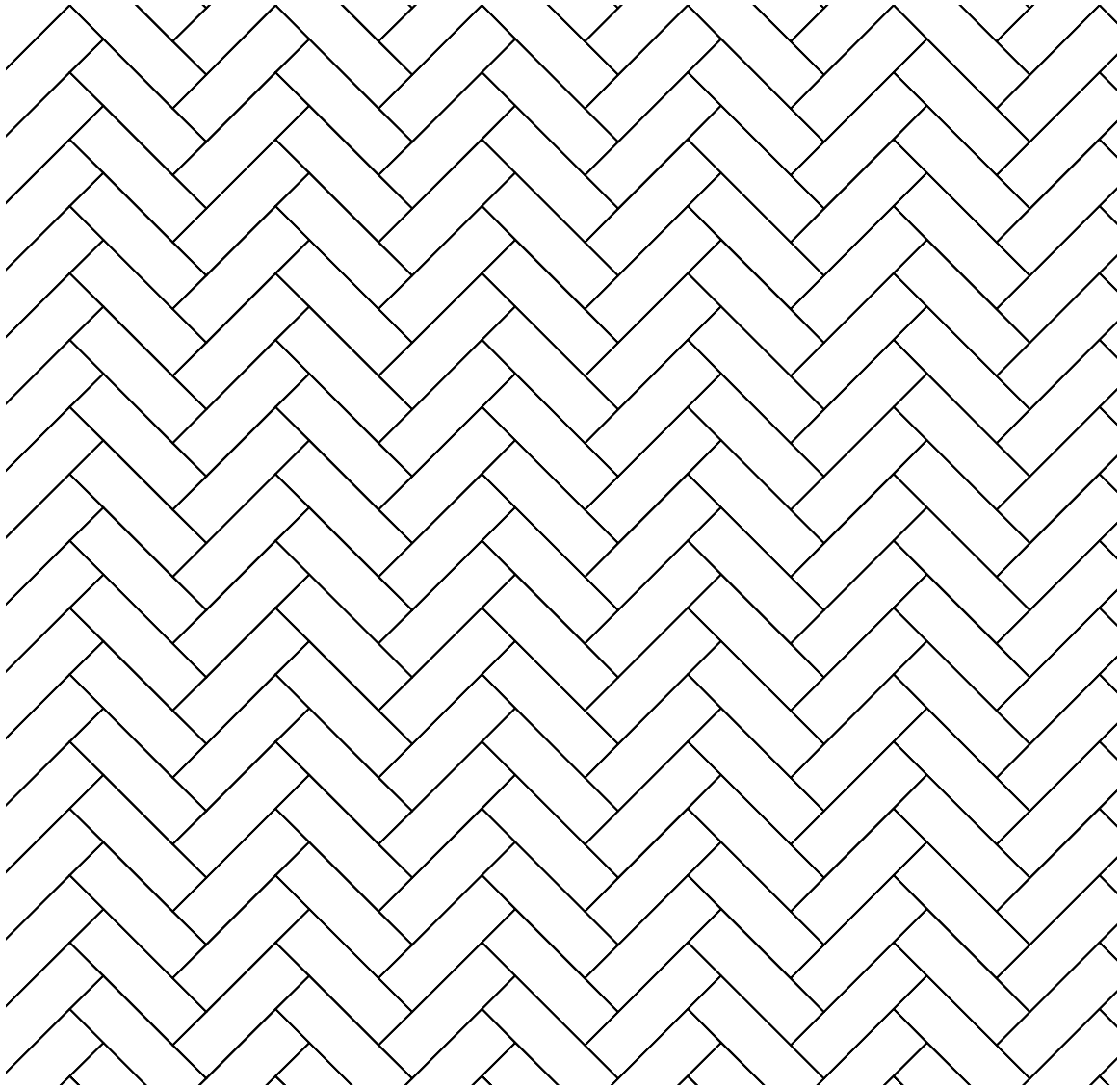

Figure 17: Material precedent

Figure 18: Laying pattern



Product	Dutch clay paver
Bond	Herringbone
Dimensions	200 x 65 x 85mm
Material	Neland Dutch clay, in Auraton colour
Finish	Baked clay
Joints	Butt jointed, kiln dried sand
Supplier	Hardscape www.hardscape.co.uk / 01204 565 500

PRE CAST CONCRETE PAVING

The area outside of the Student Union is a hub of activity. A custom pre cast concrete paver gives a contemporary twist to the space which needs its own identity.

Figure 19: Material image (note: larger scale units shown)



Figure 20: Material precedent

Figure 21: Laying pattern

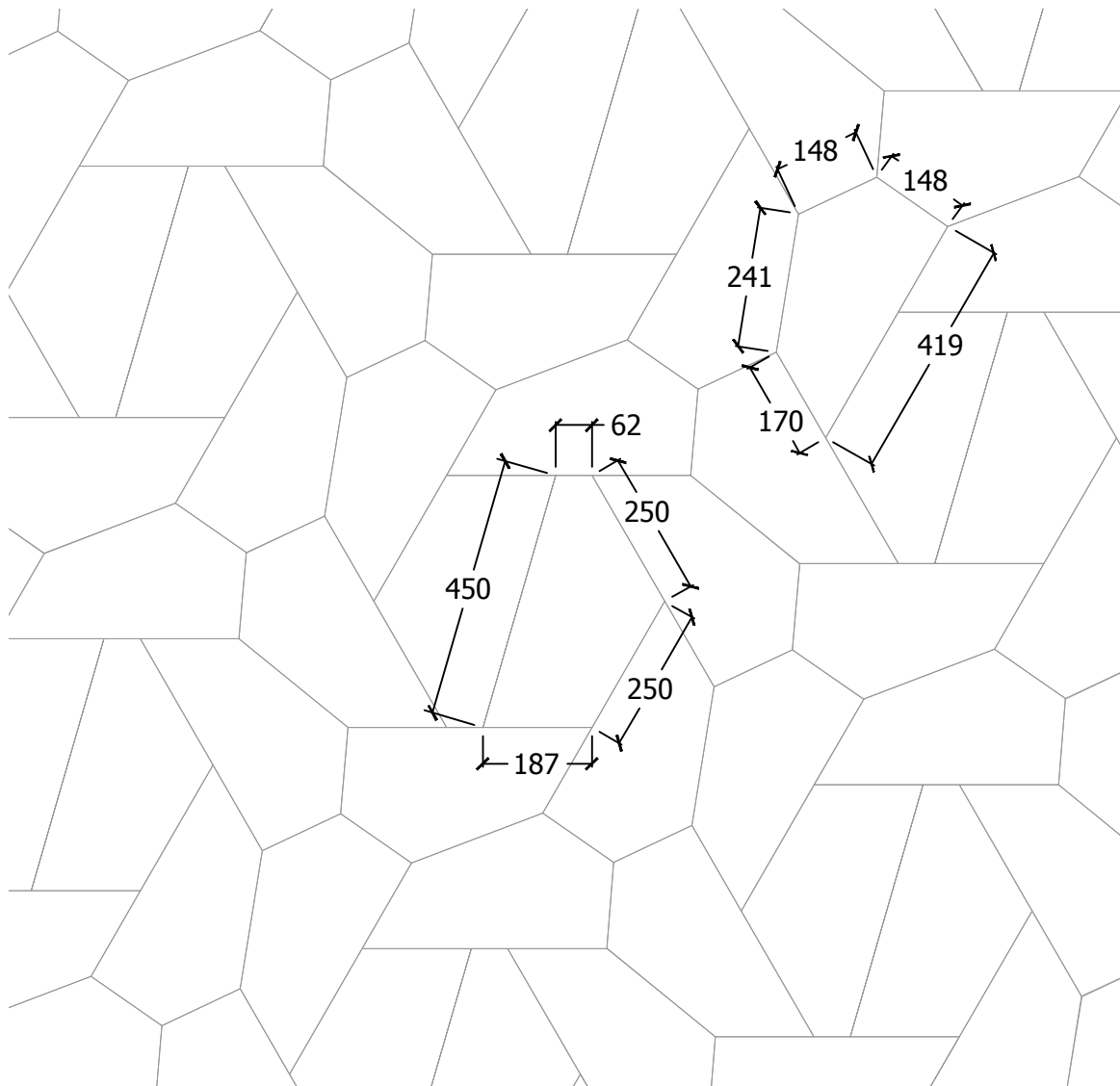

Product	Bespoke trapezoid pre-cast concrete paving units
Dimensions	2 units, as shown
Material	Pre-cast concrete
Finish	Acid etched
Joints	Butt jointed, kiln dried sand
Supplier	Hardscape (contract: Dave Lowe) www.hardscape.co.uk / 01204 565 500

PCC TRIM TO CENTRAL SQUARE

The junction between the central square and the frame is served by a wide concrete unit which could have a graphic imprint placed on its surface.

Figure 22: Material precedent detail



Figure 23: Material precedent

Figure 24: Laying example

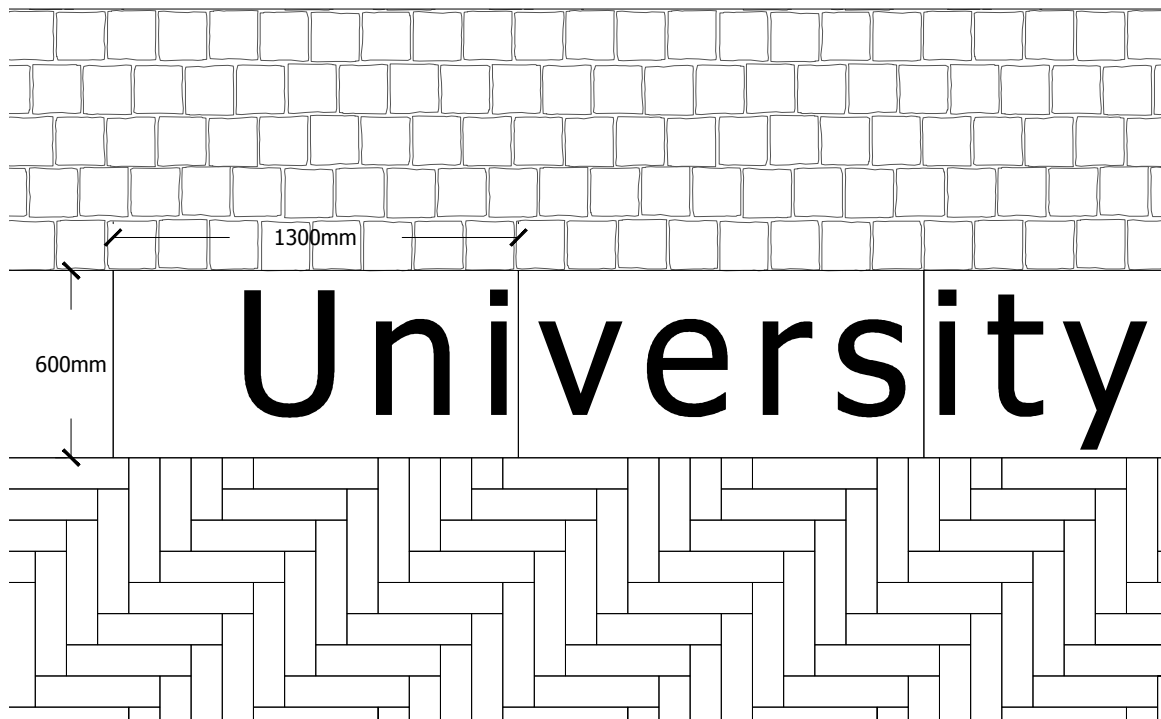

Product	Pre-cast concrete trim
Dimensions	1200 x 650 x 200mm
Material	Pre-cast concrete
Finish	Cast in graphic art (TBC)
Joints	Recessed 5mm mortar joints
Supplier	Sterling Services (contract: Chris Bell) www.sterlingservicesltd.com / 0118 9502330

GRANITE PAVING

When a main entrance to a building faces the quads, an area of high quality granite pavers is used to demarcate the access point.

Figure 25: Material image



Figure 26: Material precedent

Figure 27: Laying pattern

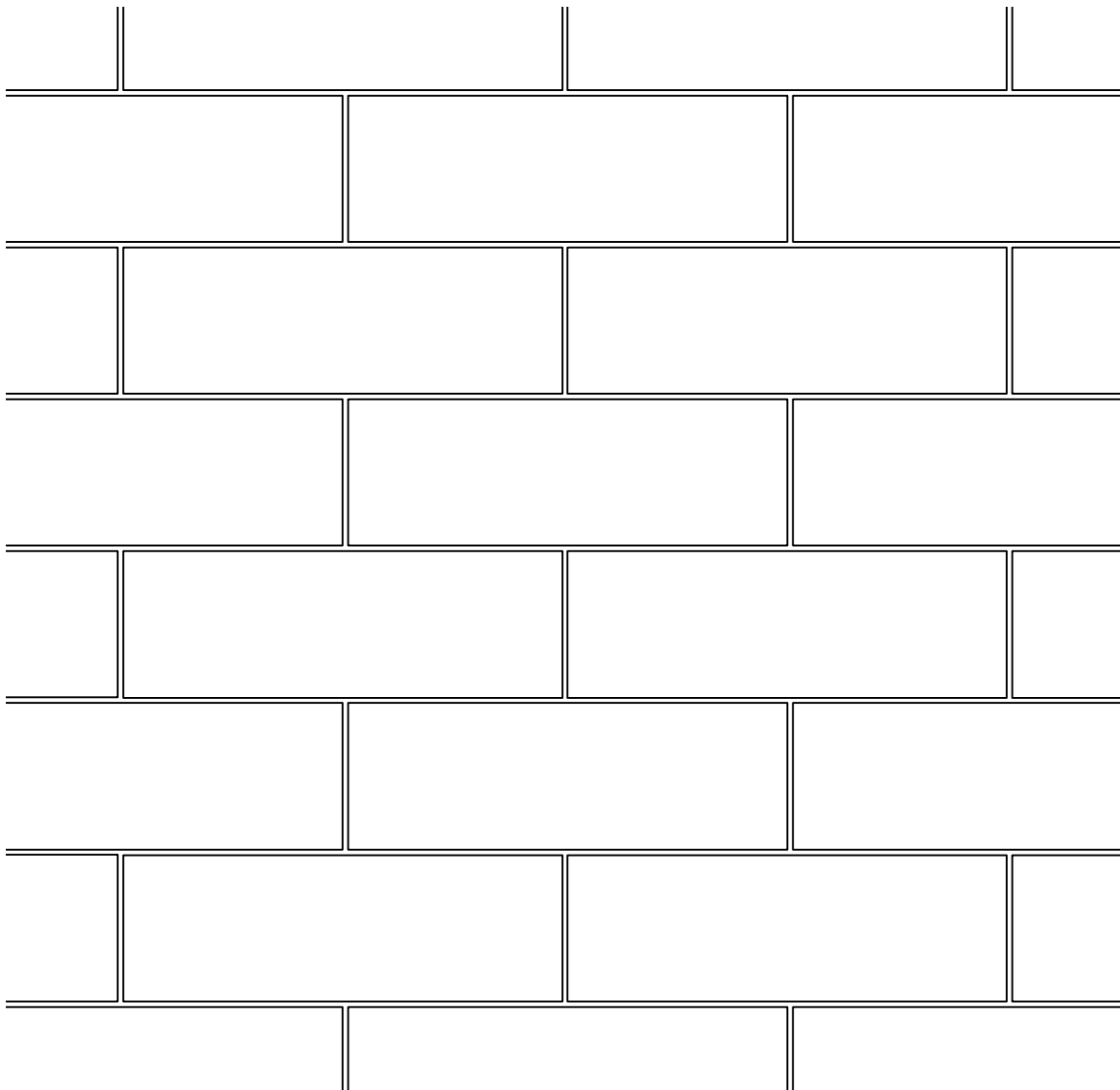

Product	Kobra granite
Bond	Stretcher course
Dimensions	600 x 200 x 37mm
Material	Granite
Finish	Sawn base and sides, flamed top
Joints	7.5mm High strength flood grouted mortar joints and mortar bed.
Supplier	Hardscape (contract: Dave Lowe) www.hardscape.co.uk / 01204 565 500

TARMACADAM

Used extensively in the URS quad. Tarmacadam is a hard wearing and economical material.

Mix to Engineer specification

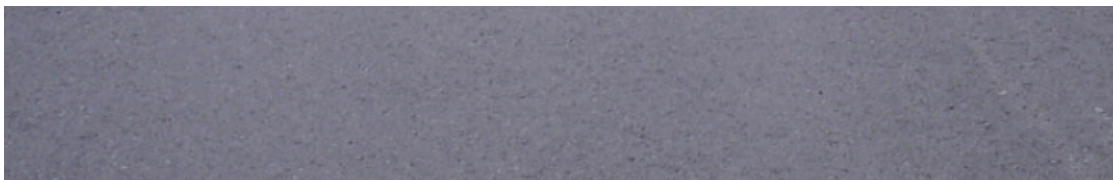

SELF BINDING GRAVEL

Self-binding gravel offers an alternative to lawned areas by providing a soft surface that can be planted with trees.

50mm depth CEDEC gravel compacted on Type 1 sub-base.



BLACK GRAVEL

Used as a border between tarmacadam and grass in the URS quads.

20mm loose laid black basalt gravel 100mm depth on terram geotextile layer

(shown dry and wet)



* Sufficient edge detail along side soft landscaping to reduce the risk of gravel coming in contact with maintenance vehicles

RESIN BOUND GRAVEL

Resin bound gravel is used in the library garden area.

Scandinavian Pearl 3mm aggregate

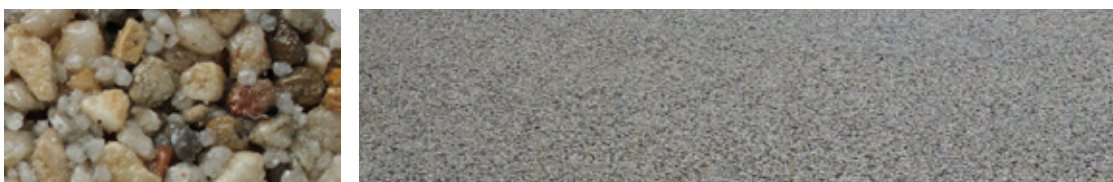

EDGING & DRAINAGE

Edging

All paths and areas of hard surface to be edged with pinned aluminium edging.



Slot Drain

In general drainage to hard surface areas should be provided by means of Aco Multi-drain brickslot type drains.



Recessed Drain Cover

Laid square in line with paving away from paving edges. Cut units to continue pattern seamlessly. Not to straddle two material types.



FURNITURE SELECTION

PICNIC TABLE

The 'picnic' tables will be provided outside existing and new catering locations such as the new library cafe.

Figure 28: Plan view and elevation

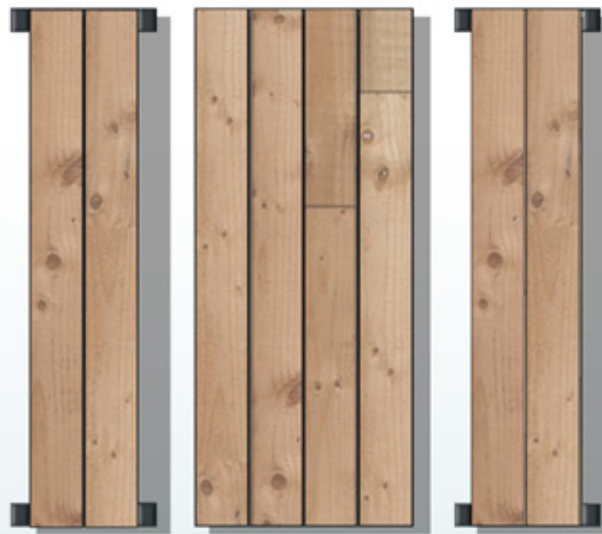

Figure 29: Product images



Product	'Campus levis' table and benches
Dimensions	Table 2180 x 804 x 780mm, bench 2180 x 575 x 480mm
Material	Aluminium frame with hardwood top
Colour	Powder coated; anthracite grey, RAL 7016
Fixing	Treated steel bolts with epoxy fill (into concrete footings below modular paving)
Configuration	Two benches to every table unit
Supplier	Manufactured by Westeife, supplied by Bailey Streetscene www.baileystreetscene.co.uk / 01625 855900

BOLLARD

The provision of bollards will be required to control unauthorised vehicular movements. A drop bollard version of the fixed bollard is available.

Figure 30: Product illustration



Figure 31: Product images



Product	'Lot' bollard
Dimensions	1000 x 60 x 60mm
Material	Steel construction
Colour	Powder coated; anthracite grey, Powder coated steel RAL 7016 with RAL 3028 contrast strip.
Fixing	Ground fixed, steel plate bolted to concrete base under pavement finish,
Configuration	Bollards arranged according to plan with optional drop down bollard, secured with 1602 padlock.
Manufacturer	mmcité www.mmcite.com / 07401 575 290

WASTE BIN

The University requires bins capable of receiving 2 waste streams. General non recyclable waste will be held in one bin with an adjacent bin holding recyclable waste. Each bin will be grey with the capacity to have bespoke adhesive graphics applied. An integrated cigarette butt bin is provided.

Figure 32: Product illustration



Figure 33: Standard product images



Product	'Derby' Double Slimline Recycling Bin
Dimensions	1020 x 420 x 770mm, 80L Double waste stream ,160L total
Material	Steel construction
Colour	Powder coated; anthracite grey, RAL 7016 (standard Broxap colour) Surface to be capable of accepting bespoke applied graphics
Fixing	Anchor bolted to base
Configuration	Double waste stream. Rectangular aperture for general was and round aperture for recycling with built ashtray to top of unit.
Supplier	Broxap www.broxap.com

*For further information refer to the University:
Waste Management Specification for New Builds and Refurbishments

CAFE SEATING

Across the Quads a number of locations provide opportunities for informal clusters of tables and chairs. These will provide splashes of colour contrasting with the general subdued colour applied to the majority of the furniture palette.

Figure 34: Plan view and elevation

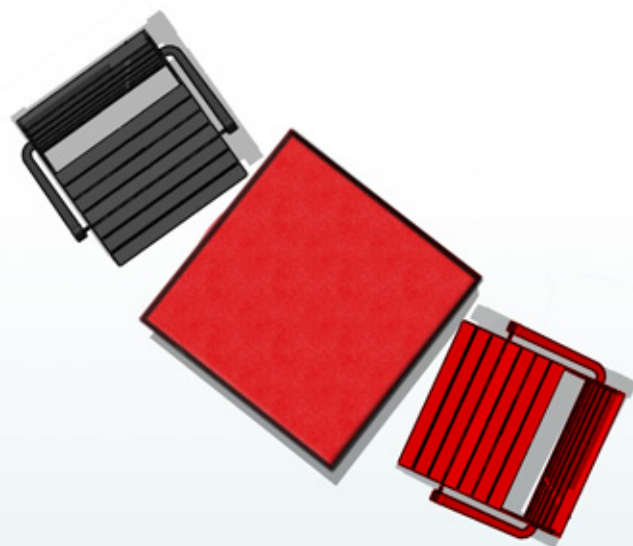

Figure 35: Product images



Product	'Parco' chair
Dimensions	777 x 560 x 509mm
Material	Steel plate structure
Colour	Powder coated; red, RAL 3028 & 7016
Fixing	Casting in ground
Configuration	Two, three or four seats centred around Berlin tables
Supplier	Nola www.nola.se

Product	'Berlin' table
Dimensions	740 x 800 x 800mm
Material	Steel construction
Colour	Powder coated; red, RAL 3028 & 7016
Fixing	Casting in ground
Configuration	Tables arranged between chairs
Supplier	Vestre www.vestre.com

CYCLE HOOP

Cycle hoops add dramatic sculptural interest through the use of bright red 'loop' bike stands which stands out from the anthracite grey of other pieces.

In enclosed cycle stores standard Sheffield cycle stands will be used.



Figure 36: Product illustration



Figure 37: Product images



Product	'Key' cycle hoop
Dimensions	800 x 570 x 70mm
Material	Steel core with HDPE foam coating, powder coated steel base
Colour	Red foam coating; anthracite grey RAL 7016 finish to cast aluminium base
Fixing	Two treated steel bolts with epoxy fill (into concrete footing below modular paving)
Configuration	Arranged in grid formation to Landscape Architect's plan
Supplier	Santa & Cole www.santacole.com

CUSTOM BENCHES

Within Palmer Quad the outline designs envisage a series of dramatic sculptural benches. These benches will fulfil a range of functions and will be bespoke pieces. At this stage a number of models have been produced to examine potential forms. These will be resolved into finalised designs in conjunction with key stakeholders.

Figure 38: Product illustration



Figure 39: Initial Model Options



Product	Custom made bench solution
Dimensions	To be determined
Material	Steel frame, treated hardwood slats
Colour	Powder coated steel; anthracite grey, RAL 7016
Fixing	Bolted to concrete base
Configuration	Arranged to Landscape Architect's plan
Manufacturer	To be determined

BIKE SHELTERS

Bike shelters will be provided across the Quads. These shelters have been designed to provide both enclosed storage and covered storage with open sides.

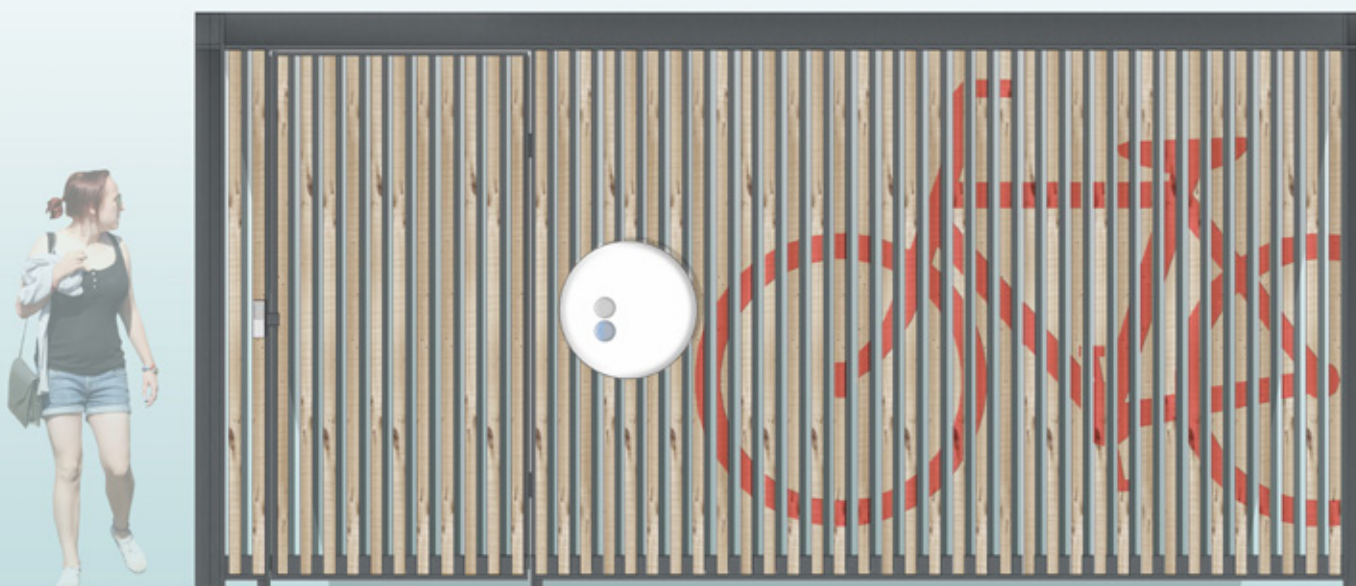

Product	Custom made bike shelter
Dimensions	To be determined
Material	MIO coated steel, oak slats Sioox treated
Colour	Powder coated steel; anthracite grey, RAL 7016 Painted bike graphic, matt finish RAL 3028
Fixing	Bolted to concrete base
Configuration	Arranged to Landscape Architect's plan
Manufacturer	To be determined

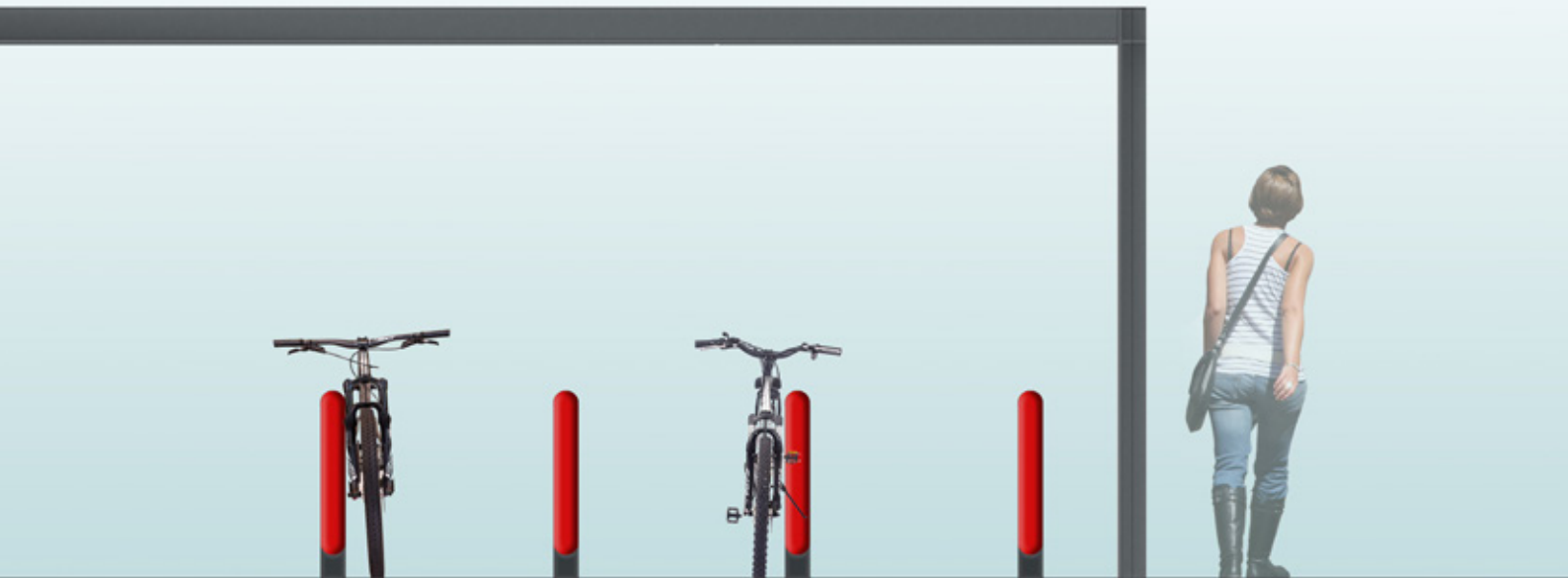

Lighting Selection

Objectives Summary

The objective of this lighting report is to establish lighting design principles as a framework for further design development for this project. The final outcome will be the balanced use of light across the development, providing a vibrant, welcoming and sustainable lighting installation.

This Lighting Report starts to set out the essential Design and Technical Guidelines which will be followed in the further design development of lighting across this project. It has been developed in conjunction with the Client and associated design team members.

The principle elements to be considered for lighting across this development are;

- Buildings
- Streets
- Spaces

Each of these elements will impact on the other. The most successful urban lighting designs allow each element to be satisfactorily illuminated whilst acknowledging the needs of adjoining buildings, streets and spaces.

The lighting to each of these elements will be designed according to the following criteria;

- Character and Ambiance
- Balance
- Legibility and Way Finding
- Sustainability
- Safety and Security
- Buildability

Character and Ambiance

Lighting will support and enhance the character of The University of Reading during the hours of darkness – providing a welcoming environment consisting of a series of buildings, streets and spaces.

Balance

The development provides residential accommodation, retail, working and socialising opportunities. Each of these require different lighting requirements in order they provide the appropriate level of night-time ambiance.

Legibility and Way Finding

Lighting will be designed to encourage the exploration of public areas with consistent quality, permitting instinctive navigation and orientation.

Sustainability

The selection of good quality, efficient light sources and lighting equipment and the intelligent use of a site wide control system will ensure satisfactory lighting is always provided. Running and maintenance costs will be consistently reduced and light pollution minimised through considerate design and installation.

Safety and Security

The careful balance and contribution of lighting from a variety of locations and sources creates a cohesive visual environment, allowing residents, workers and visitors to easily navigate the site with peace of mind. Lighting will be designed to support the technical requirements of CCTV coverage.

Buildability

By creating a master plan of how each building, street and space will be illuminated, lighting equipment and supporting cabling infrastructures can be integrated in the most efficient locations, reducing lighting equipment quantities and building complexity. Robust, long Life lighting equipment will be specified and all fittings will to be easy to install and maintain.

Existing Lighting Equipment

Following a site visit we have reviewed some of the existing lighting equipment located around the central space and the main approach road. This lighting is very functional in appearance and performance. The unappealing 'green' lighting columns are approx 5m high and located at very wide spacings between columns and whilst lighting calculations have not been produced it is our opinion that the central public realm space is currently under illuminated and not in-line with latest lighting codes and standards. We understand some of the road lighting columns have recently been changed to utilise LED technology and further investigation is needed to ensure that any palette of equipment takes this into consideration to avoid replacement.

Any new lighting arrangement would need to meet these requirements as well as any CCTV and security facial recognition requirements. The columns utilise older lamp technology and as a result are using more energy, carbon and creating greater running cost (electricity and maintenance) than a new lighting scheme would.

We also note that the existing site has a mix of lamp types and colour temperature (different tones of white light). It is important to the night time environment that the colour temperature is consistent across the site.

There appears to be no feature or accent lighting within the site and minimal lighting attached to buildings. We feel this is a missed opportunity as a small amount of this type of lighting would go a long way to increase the general appearance and atmosphere.

The campus has a large range of luminaire suppliers and consideration should be given to updating this list. An updated list which is created in-line with a developed Lighting Design Guide for The University of Reading would provide the opportunity to reduce the quantity of suppliers and introduce new LED focused suppliers. It is still important that any list has more than one supplier to ensure there is competition at tender stage however consideration needs to be given to which manufacturers are on the list as it is equally important for the overall appearance of the University to provide visual and lighting performance consistency.

The following pages provide the first steps to outline a lighting design approach and type of lighting equipment that should be used to improve, and enhance the appearance of The University of Reading.



Layers of Light

To achieve the correct quality and quantity of lighting for buildings, streets and spaces, a combination of ambient, accent and feature lighting is required to create the balance between functional and aesthetic lighting.

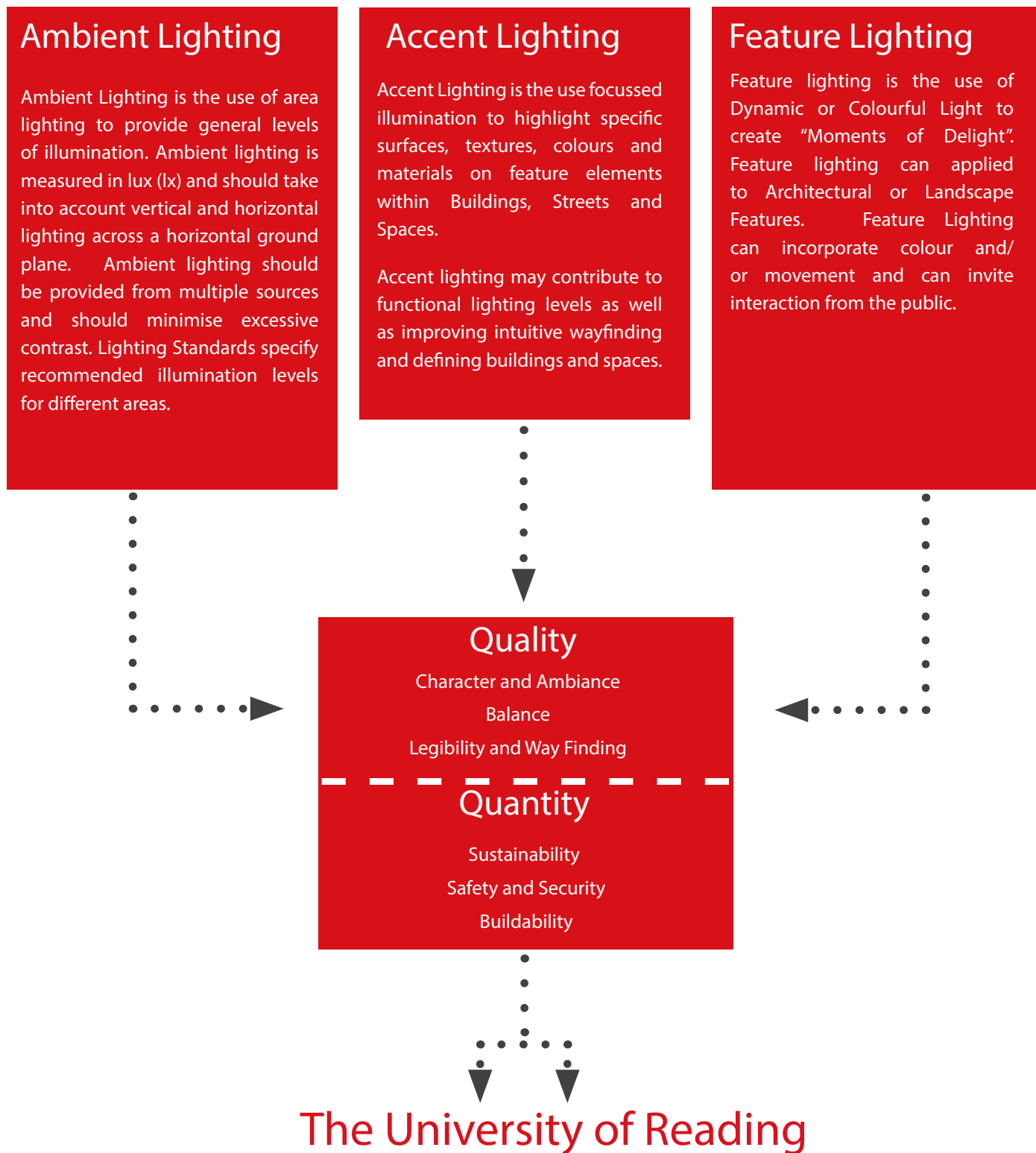

Ambient Lighting

Ambient Lighting is the use of diffuse illumination to provide background illumination for all users of the restaurant. Ambient lighting is measured on the horizontal plane in lux (lx) and should minimise shadows and contrast. Lighting Standards specify illumination levels for different areas.



Accent Lighting

Accent Lighting is the use of focussed illumination to highlight specific surfaces, textures, colours and materials on feature elements within Buildings, Streets and Spaces. Accent lighting may contribute to functional lighting levels as well as improving intuitive wayfinding and defining buildings and spaces.

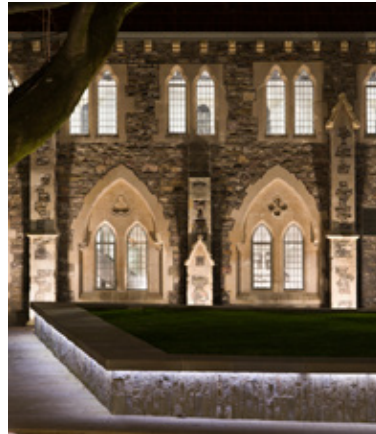

Feature Lighting

Feature lighting is the use of Dynamic or Colourful Light to create “Moments of Delight”. Feature lighting can be applied to Architectural or Landscape Features. Feature Lighting can incorporate colour and/or movement and can invite interaction from the public.

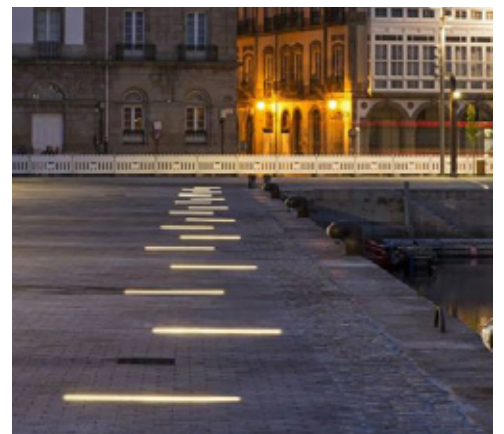

Sample Area 1



Primary and Secondary Pathways

The equipment type should be selected to complement the pathway width and the location around the University site as well as consider the other luminaries already in use in the immediate surrounding area - to ensure there is a consistent visual appearance.

Where the University has pathways through the grounds that are not located next to roadways a more pedestrian sized, more aesthetically pleasing and less functional looking column type should be used. These areas are about people movement so the lighting should respond accordingly.

In these locations consideration should be given to illuminating some planting and trees. This is to create a more relaxed atmosphere. Tree up lighting provides the opportunities to break up the functional approach of the pathway lighting. It adds a layer of accent lighting and interest by providing soft up lighting to the Universities key landscape elements.

The images opposite cover a selection of products which create the type of look and feel we believe the public realm / landscape areas should be designed in-line with. Please refer to the equipment pages later in the document for more detail.

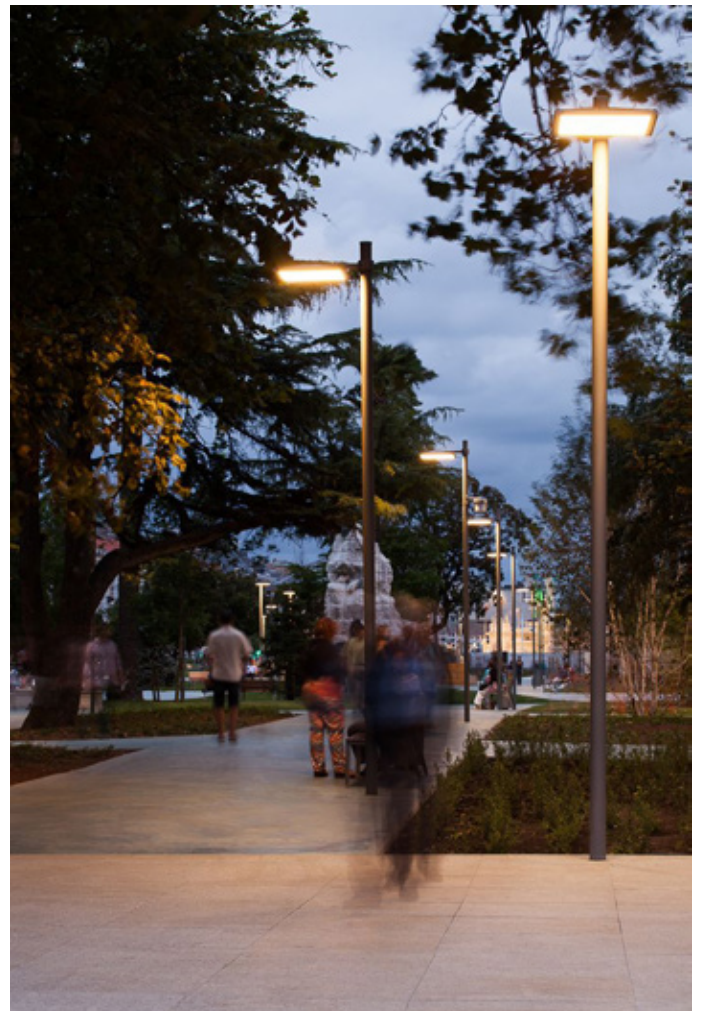

Sample Area 2

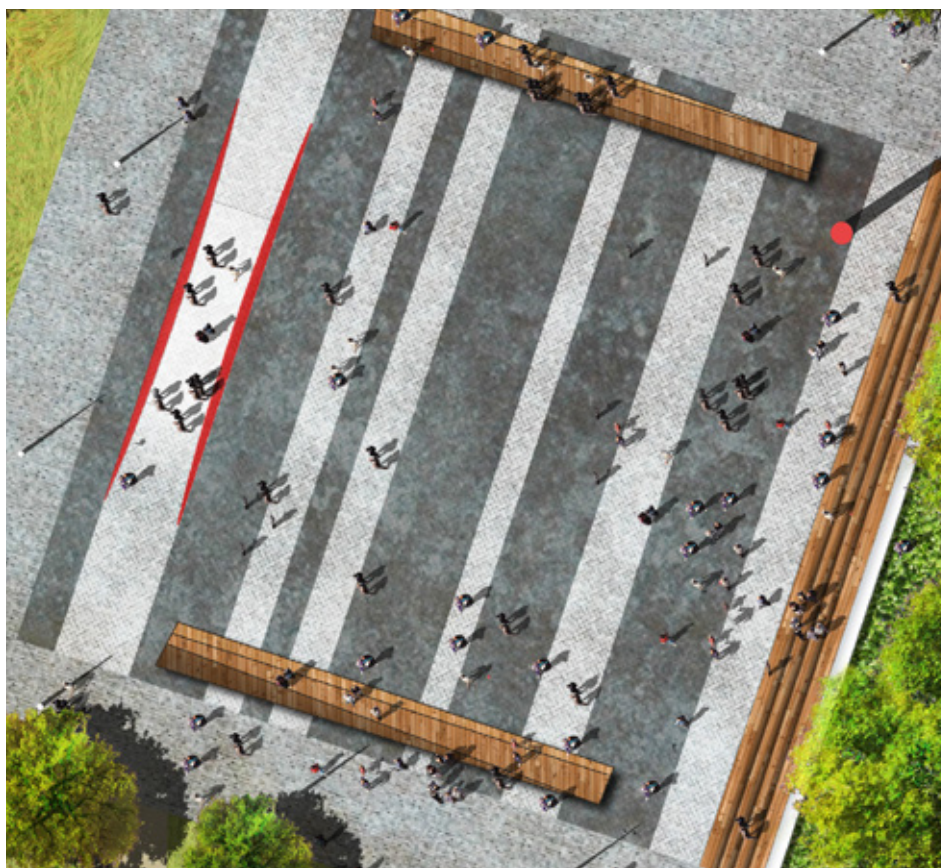

Open Spaces and Squares

The lighting to any large open space needs to be carefully considered with the landscape design to ensure the scale, location and approach of any lighting equipment is complementary to the overall vision and use of the space. In principle a larger single lighting column can illuminate a space as long as it is also supported by a secondary light source. The secondary light source could be integrated into the surrounding seating by having light washing down and out across the floor. Both lighting elements would help create a strong night time presence and one that took on a different appearance by day and night.

Where possible we would look to have a single lighting effect provide both the ambient and accent lighting layers - as per the Gobo projection images opposite.

The images opposite cover a selection of products which create the type of look and feel we believe the public realm / landscape areas should be designed in-line with. Please refer to the equipment pages later in the document for more detail.

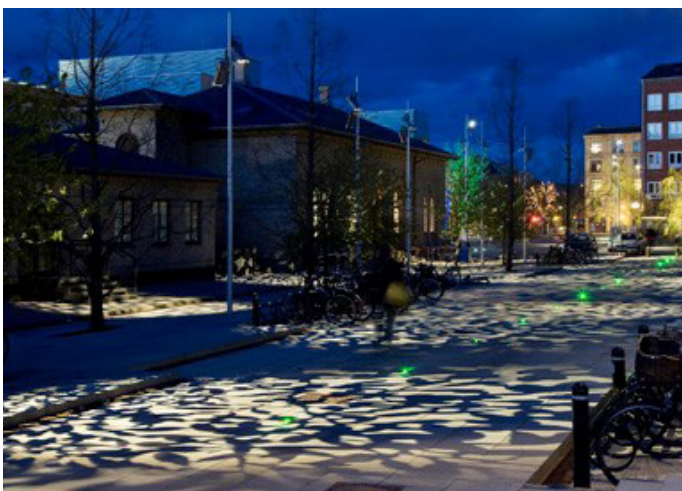

Sample Area 3

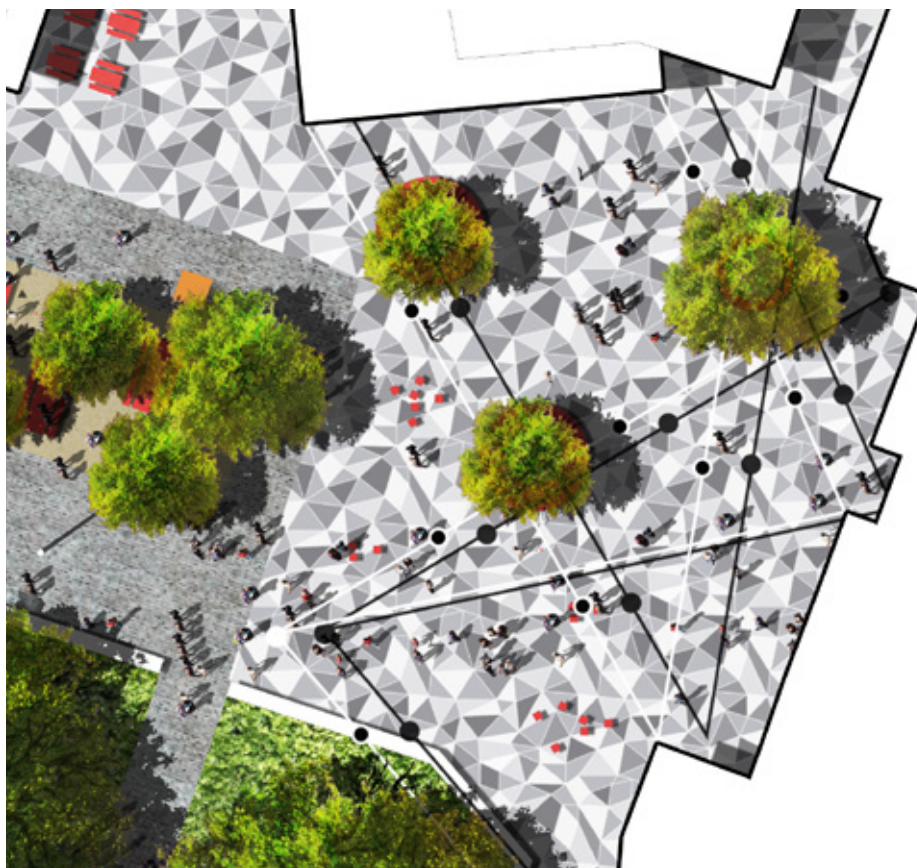

Building Entrances and Forecourts

The building entrances and public forecourts in front of the building provide the opportunity to ensure the lighting leads people up to and into the building. The light levels should increase as you approach the buildings to both encourage people movement and provide the transition threshold between internal and external spaces. This can be achieved in many ways and the lighting needs to be complementary to both the landscape and the building. With certain buildings it may be appropriate to illuminate the entire facade, parts of the facade or just the entrance. Equally with buildings that have a glazed frontage it is important the lighting design takes consideration of the quantity of 'borrowed' light coming from the building.

If any of the buildings have a larger public realm space or forecourt in front of the building consideration should be given to enhancing the night time appearance and building entrance by looking at lighting approaches that are tailored to this location.

The images opposite cover a selection of products which create the type of look and feel we believe the public realm / landscape areas should be designed in-line with. Please refer to the equipment pages later in the document for more detail.



Selected Equipment Types

Pathways and Pedestrian Routes

The paths and pedestrian route through the University grounds would be illuminated via approx 3 to 4m lighting columns. Columns at this size would be more in keeping with a public realm environment and be of a 'human scale'. We believe that a clean modern looking lighting column would complement the landscape design and the overall University environment. The choice of luminaire head / design is to be agreed with the University in terms of aesthetic appearance and the two images opposite we believe would provide the best approach and appearance.

The columns will direct the light downwards onto the path to ensure there is no/minimal light spill and pollution into the surrounding buildings, and natural habitat. The lamp type would be LED to provide extra long lamp life (reducing maintenance cycles), lower energy consumption and lower carbon output.

We understand the University are keen to utilise hinged columns so that the lighting can be maintained from the ground. This is possible with most types of luminaire heads and should be considered along with the visual appearance of the columns. The lighting columns would have their own photocell to switch the light on / off at dusk and dawn.

Lighting calculations and lux models need to be created to confirm the quantity of luminaries required to meet the latest ambient lighting codes and standards.



Product Supplier - Iguzzini Lighting

Product Reference:

iTeka Luminaire - BV22 - 16.8W - 3000K - ST1.0 - IP66-
Photocell Controlled. Complete with 3500mm base hinged
column in RAL 7016.

David Griffiths - Iguzzini Lighting UK

M: 07850 319459 - David.Griffiths@iguzzini.co.uk

Product Supplier - Bega Lighting

Product Reference:

Light Building Element - 88064 (3.5m column) - 36W - 3000K
- IP65 - Photocell Controlled. Complete with 3500mm base
hinged column in RAL 7016.

Neil Kirwan - Marshalls PLC

M: 07812 364711 / Neil.Kirwan@marshalls.co.uk

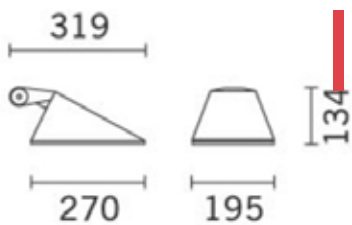

IN ABEYANCE

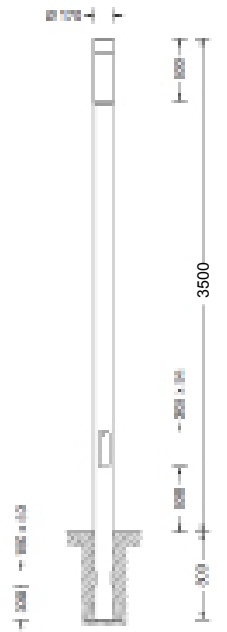
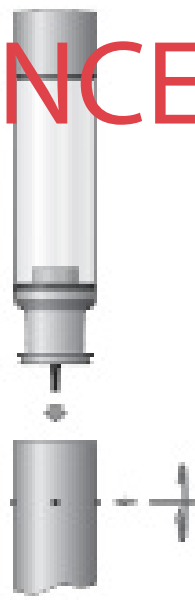

Selected Equipment Types

Pathways and Pedestrian Routes

Where appropriate public realm spaces around building entrances, cafés / spill out areas and areas of low or no vehicular movements should consider use of low (1m) level bollards. Illuminated bollards could be used to clearly identify a route through a park or up to a building as well as complement light levels in areas that are designed to be 'dwell' spaces such as pocket parks and outside seating (cafés). The design and appearance of the bollard should be in keeping with the columns to create visual consistency in equipment.

The bollards would direct the light downwards onto the path / area to ensure there is no/minimal light spill and pollution into the surrounding buildings, and natural habitat. The lamp type would LED to provide extra long lamp life (reducing maintenance cycles), lower energy consumption and lower carbon output.

Lighting calculations and lux models need to be created to confirm the quantity of luminaries required to meet the latest ambient lighting codes and standards.

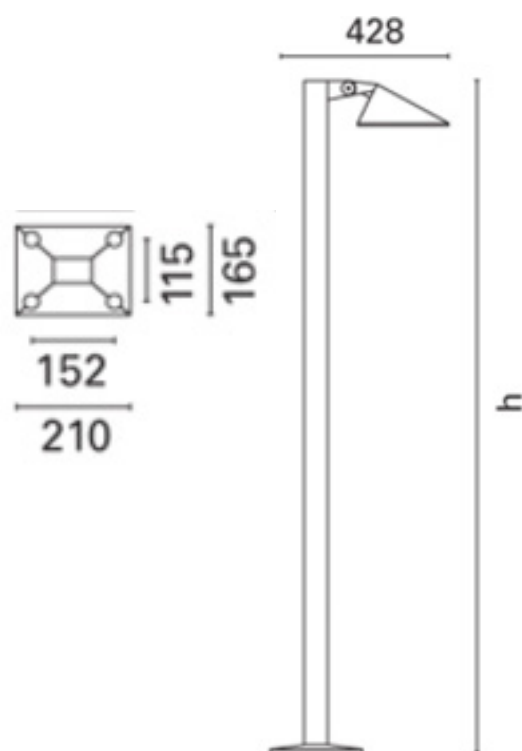
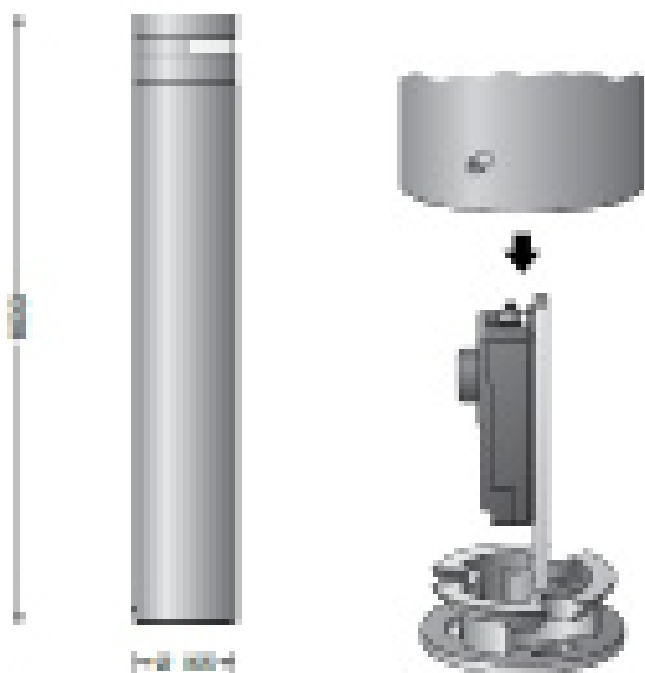

Selected Equipment Types

Open Spaces / Squares

The lighting to any large open space needs to be carefully considered with the landscape design to ensure the scale, location and approach of any lighting equipment is complementary to the overall vision and use of the space. In principle a larger single lighting column can illuminate a space as long as it is also supported by a secondary light source.

As these spaces tend to be the centre / heart of the development they can consider a different more exciting and visually interesting lighting approach. Equally these types of spaces are often used for events which suits a different lighting approach.

We are proposing Gobo lighting is used from a single large lighting column. Gobo lighting provides a patterned light array onto the floor and surfaces. The options of pattern is endless and can be designed to suit any requirements. The approach is to use this Gobo lighting as the ambient lighting to the space - utilising a single lighting source to create the ambient and accent lighting layers (functional and feature).

The luminaries would direct the light downwards into the space to ensure there is no/minimal light spill and pollution into the surrounding buildings, and natural habitat. The lamp type would be LED or metal halide to provide long lamp life (reducing maintenance cycles), lower energy consumption and lower carbon output. The lighting column would have its own photocell to switch the light on / off at dusk and dawn.

Lighting calculations and lux models need to be created to confirm the quantity of luminaries and the height of the column required to meet the latest ambient lighting codes and standards.

Consideration should be given to additional temporary lighting power supplies for movable event lighting.

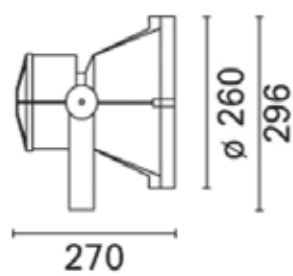
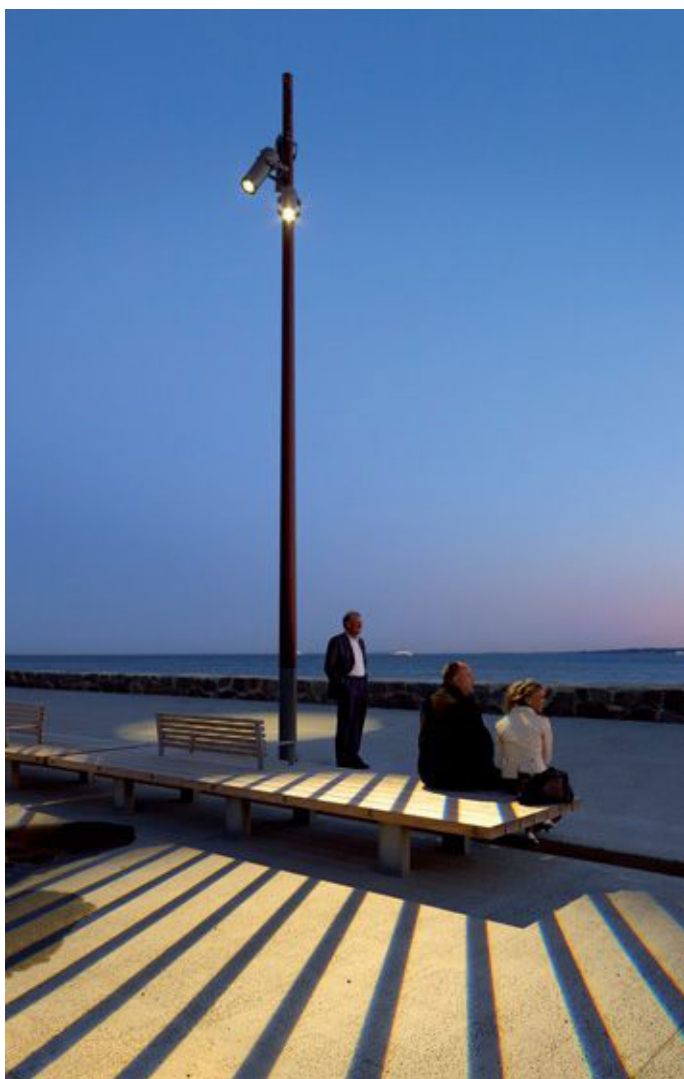

Selected Equipment Types

Open Spaces / Squares

The use of integrated bench lighting can be used to both provide ambient and accent lighting to a space. In large open spaces this additional layer of lighting can be used to contribute to the lighting levels provided by the larger lighting column(s). The integration and location of the equipment needs to be carefully considered with the landscape design to ensure the lighting can be securely fixed and is adequately protected.

Bench lighting can be used to create a pleasant low level atmosphere to encourage pedestrians to use seating at night.

The luminaries would direct the light downwards into the space to ensure there is no/minimal light spill and pollution into the surrounding buildings, and natural habitat. The lamp type would be LED or metal halide to provide long lamp life (reducing maintenance cycles), lower energy consumption and lower carbon output.

Lighting calculations and lux models need to be created to confirm the quantity of luminaries required to meet latest lighting codes and standards.

Consideration should be given to additional temporary lighting power supplies for movable event lighting.

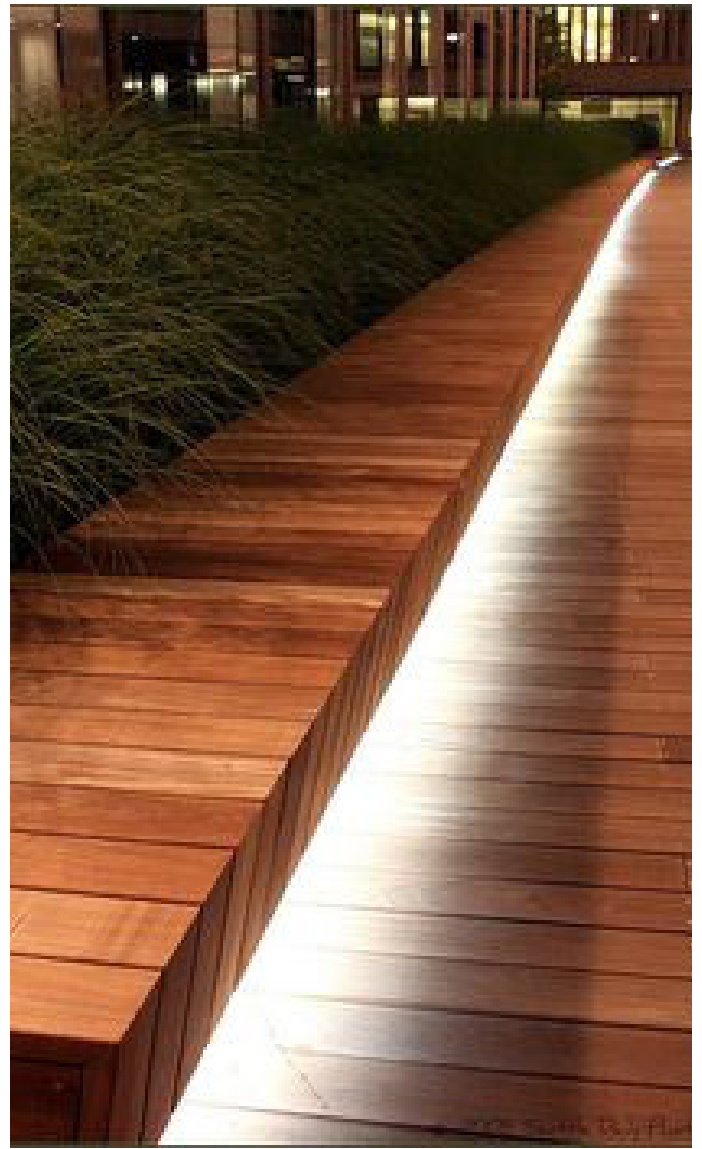

Selected Equipment Types

Tree and Foliage Lighting

Tree and foliage lighting helps to create a pleasant and calming atmosphere. It can also be used to aid way finding by 'marking' entrance points / destinations into a space or development.

We believe that selected trees around the campus and central space should be illuminated at night.

Any tree lighting needs to consider the wildlife (bats) to ensure that it is appropriate for illumination. All tree lighting should also have a time clock connected to the electrical distribution outlet to enable it to switch off at approx midnight. This saves electricity and allows the wildlife and tree to have a period of natural darkness.

The detail of lighting installations within RPA's of existing trees should be agreed with an arboriculturalist and the University Ground Maintenance team to prevent damage to roots.

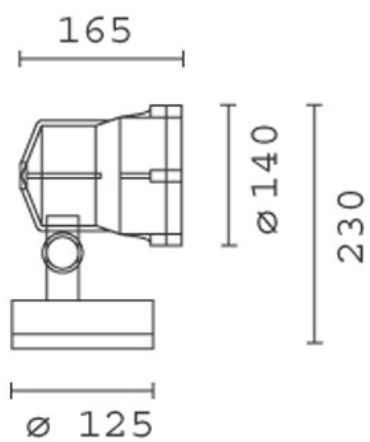
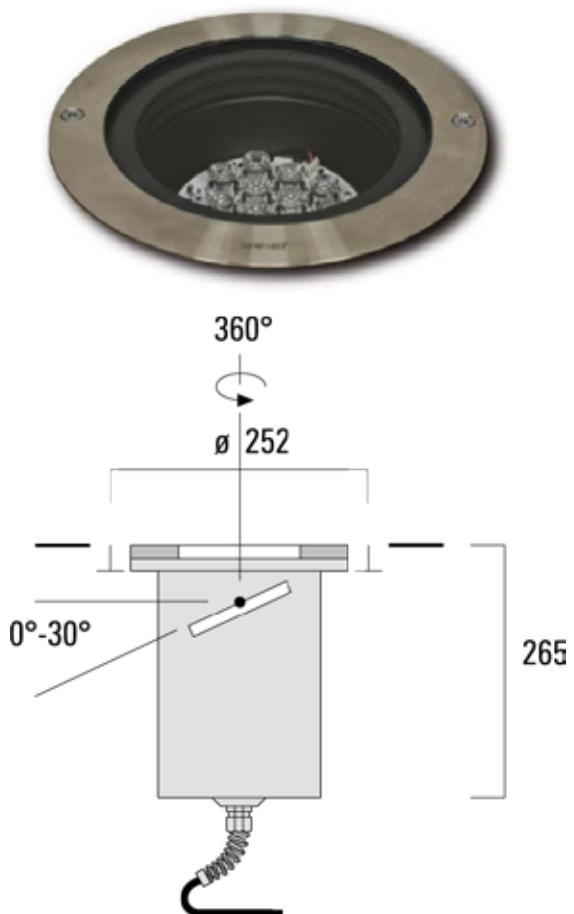

Selected Equipment Types

Building Lighting

A small amount of feature lighting on key buildings will help enliven the building, aid way finding, add interest, create the feel of a brighter environment and create a softly illuminated backdrop to the overall public realm environment by night.

The type of illumination and lighting approach should be complementary to the building style, age, location and design. The University grounds have a mixture of historic and 20th century buildings. Some of these buildings are sat within key vistas of the University grounds, both from the surrounding and approach roads as well as internally within the campus and some lighting onto these buildings would help provide a welcoming and interesting look and feel.

The images opposite are intended to start a conversation regarding which buildings the University see as important to have a night time presence. They also offer some options in terms of lighting styles and approaches.



Technical Considerations

Technical

During the design process, lighting equipment locations will be integrated wherever possible in buildings, structures and appropriate built forms - reducing the visibility of lighting equipment and helping the built environment appear more visually cohesive and pleasing to the eye.

Considerations affecting the lighting designs and equipment selections include;

- Ensure Lighting locations are considered carefully to ensure both aesthetic balance and technical efficiencies are achieved.
- The location must be chosen with due regard to access, maintenance, safety and cable routes.
- Where possible, the location should be concealed. It is worth seeking out smaller, compact equipment to achieve concealment, particularly when using close-offset fittings.
- The fitting selected and the location should ensure glare to users is minimised. Where necessary, glare reducing devices such as cowls or louvres should be utilised.
- Fittings should be finished in a colour which matches that of the building structure on which they are fixed.

Lighting Equipment

- All lighting equipment will be selected to exhibit as small an appearance as possible. The design intent is to have a lighting effect rather than a display of lighting equipment.
- The choice of lighting equipment and light source is a critical part of the lighting design process. It is a primary goal to ensure the best possible lit environment is created using the lowest possible energy consumption and minimised light spill and light pollution. To achieve this, specific lighting products will be selected to perform specific functions. Factors that will be taken into consideration when choosing the final specification;
- Light fittings must have superior optical control, using reflector design and internal and external accessories to ensure precise beam control and minimised light spill.
- Lighting equipment selected will be covered by a suitable manufacturers warranty and should possess sufficient

operational life to suit operational criteria.

Lighting equipment will be mounted in easy to access conditions. It is important that the fitting can be maintained without unnecessary effort.

- All fittings must demonstrate value for money

Light Sources

- Colour Appearance - this is simply what colour the lighting appears to be. It is very important in creating overall effect.
- Colour Rendering - the ability of the light to render colour accurately. Although less important in exterior lighting, poor colour rendering can have a deadening effect on an area.
- Lamp Life - the average life of a lamp in a large installation. This has an Importance for maintenance costs.
- Efficacy - the output of the lamp in relation to its energy usage, measured in lumens per watt. This has often been the consideration in choosing sources, the desire being economy.
- All lamps will be latest technology, operated via energy efficient, high frequency control gear.

Lighting Control

An automated lighting control system will be selected to provide the following benefits;

- The selective dimming of all lighting will reduce energy consumption, greatly increase lamp life, reduce maintenance cycles and lower running costs.
- Vary the intensity of selected lighting elements to vary the night-time environment, providing variation and stimulating interaction with visitors.

Operation and Maintenance

The regular maintenance of the lighting installation is of vital importance to the long term success of this strategy.

It is recommended that a co-ordinated approach to the operation of the above lighting is implemented to ensure the successful day-to-day appearance and functionality of the full lighting installation. Proposals will be developed in conjunction with the maintenance team, client and local council to ensure satisfactory operation.

Lighting Standards and Guidelines

The following Lighting Standards and Guidelines will be referenced when designing the lighting scheme and specifying lighting equipment. The following list is a minimum, additional standards may be required for specific projects.

BS5489-1: 2013 - BSEN13201-02

SLL Lighting Guide 6 :The Exterior Environment (2016)

CIE136: Guide to the lighting of Urban Areas (2000)

ILE TR24: A practical Guide to the Development of Public Lighting Policy for Local Authorities (1999)

ILE A Guide for Crime & Disorder Reduction through a Public Lighting Strategy (2005)

ILE The Outdoor Lighting Guide (2005)

BS 8300:2001 – Design of buildings and their approaches to meet the needs of disabled people

SLL/CIBSE – Commissioning Code L – Lighting (2003)

Lighting Design Fact File No. 7, 2003 - Environmental Considerations for Exterior Lighting (2003)

SLL Guide to Limiting Obtrusive Light (2012)

SLL Code for Lighting (2012)

Lighting Levels

From the above standards, the following illumination levels have been identified as appropriate for this development;

Primary Road Routes - 30 lux

Secondary Road Routes - 20 lux

Primary Public Realm Routes - 10 - 15 lux

Secondary Public Realm Routes - 5 - 10 lux

Pocket Parks - 5-10 lux

Building Entrances - 100 - 150 lux

Public Squares - 20 - 30 lux

All lux figure are based on average figure across the calculation space/areas. In-line with lighting codes and standards.



Title	28166 - ID01C Campus Design Code
Document Status:	Final
Revision:	C
Author:	MY/NO
Checked by:	CH/MY
Issue Date:	January 2018